



Hydronic* 4/5 (Coolant Heaters)

- Technical Description
- Installation Instructions
- Operating Instructions
- Maintenance Instructions
- Troubleshooting and Repair Instructions
- Parts Diagrams and List

Espar Products, Inc.
 (800) 387-4800
 (905) 670-0960
 www.espar.com

Heater Model 12 V

Hydronic D4 SC 25 2096 05
25 2257 05

Hydronic B4 SC **20 1824 05**

Hydronic D5 SC 25 1920 05
 25 2098 05
25 2219 05

FMP OUT 25 2325 05

Hydronic D5 S 25 2031 05
25 2217 05

Hydronic B5 SC **20 1820 05**

Hydronic B5 S 20 1793 05
20 1819 05

Heater Model 24 V

Hydronic D5 SC 25 2147 05

Hydronic D5 S **25 2146 05**
25 2218 05

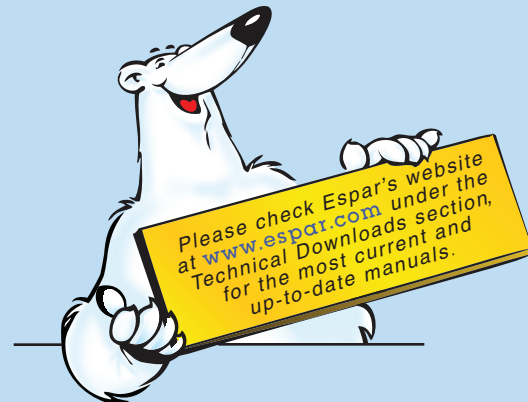

Introduction	Heater Warnings	3
	Introduction	4
	Specifications	4
	Heater Components		
	Hydronic 4/5 SC, 12 + 24 volt, Diesel	5
	Hydronic 5 S, 12 + 24 volt, Diesel + Gas	6
	Hydronic 4/5 SC, 12 volt, Gasoline	6
	Principal Dimensions	7
Installation Procedures	Heater Location	7
	Heater Mounting	8
	Heater Plumbing	9
	Fuel System	10
	Electrical Connections	12
	Exhaust / Intake Connections	13
	Control Options	14
Heater Operation	Pre-Start Procedures	15
	Start-Up	15
	Running	15
	Switching Off	16
	Safety Equipment	16
	Operational Flow Chart	17
Heater Diagnostics	Schematics	18
Maintenance / Troubleshooting / Repairs	Periodic Maintenance	24
	Basic Troubleshooting	24
	Self Diagnostic Troubleshooting	24
	Troubleshooting Chart	26
	Fuel Quantity Test	28
	Heater Disassembly / Repair Steps	29
Heater Components	Parts Diagram / Scope, Face Lift "SC" Heaters	32
	Description & Part #'s, Face Lift "SC" Heaters	33
	Parts Diagram / Scope, Face Lift "S" Heaters	40
	Description & Part #'s, Face Lift "S" Heaters	41
	Parts Diagram / Scope, Early "SC" Heaters	46
	Description & Part #'s, Early "SC" Heaters	47
	Parts Diagram / Scope, Early "S" Heaters	58
	Description & Part #'s, Early "S" Heaters	59
	Parts Diagram / Scope, North American Heaters	66
	Parts Diagram / Scope, North American Heaters (F/L)	64
Description & Part #'s, North American Heaters	66	

Special Notes

Note: Highlight areas requiring special attention or clarification.

Caution: Indicates that personal injury or damage to equipment may occur unless specific guidelines are followed.

 **Warning:** Indicates that serious or fatal injury may result if specific guidelines are not followed.



Introduction

Heater Warnings

Warning To Installer

- Correct installation of this heater is necessary to ensure safe and proper operation. Read and understand this manual before attempting to install the heater. Failure to follow all these instructions could cause serious or fatal injury.

Warning - Explosion Hazard

- Heater must be turned off while re-fueling.
- Do not install heater in enclosed areas where combustible fumes may be present.
- Do not install heaters in engine compartments of gasoline powered boats.

Warning - Fire Hazard

- Install the exhaust system so it will maintain a minimum distance of 50mm (2") from any flammable or heat sensitive material.
- Ensure that the fuel system is intact and there are no leaks.

Warning - Asphyxiation Hazard

- Route the heater exhaust so that exhaust fumes cannot enter any passenger compartments.
- If running exhaust components through an enclosed compartment, ensure that it is vented to the outside.

Warning - Safety Hazard on Coolant Heaters Used With Improper Antifreeze Mixtures

- The use of Espar coolant heaters requires that the coolant in the system to be heated contain a proper mixture of water and antifreeze to prevent coolant from freezing or slushing.
- If the coolant becomes slushy or frozen, the heater's coolant pump cannot move the coolant causing a blockage of the circulating system. Once this occurs, pressure will build up rapidly in the heater and the coolant hose will either burst or blow off at the connection point to the heater.
- This situation could cause engine damage and/or personal injury. Extreme care should be taken to ensure a proper mixture of water and antifreeze is used in the coolant system.
- Refer to the engine manufacturer's or coolant manufacturer's recommendations for your specific requirements.

ATTENTION

Operation with bio-diesel

HYDRONIC D4 / D5

HYDRONIC D4 / D5 is not certified for use with bio-diesel. Admixtures of bio-diesel up to a magnitude of approx. 10%.

ATTENTION

Heating at high altitudes

Up to 1500 meters (4920') - unrestricted heating operation is possible.

Above 1500 meters (4920') - heating operation is in principle possible for short periods, e.g. when crossing a mountain pass or during a brief stop. In cases of extended stays, the fuel supply at the fuel metering pump has to be adapted to high altitude conditions.

The following high altitude kits are available:

P/N: 24 0221 00 00 00 (Contains high altitude fuel pump)

or

P/N: 20 2900 70 00 07 (Contains high altitude compensator, no extra fuel pump needed)

or

P/N: 22 1000 33 22 00 (Only works with Hydronic Heaters that have "H-Kit" on the factory label)

Direct questions to Espar Heater Systems:

Note: Only one kit from the listed above is needed.

This publication was correct at the time of print. However, Espar has a policy of continuous improvement and reserves the right to amend any specifications without prior notice.

Introduction

Espar's Hydronic D4/D5 Heater

Quality engineered to provide a dependable means of heating, the Espar Hydronic 4/5 is a diesel fired coolant heater capable of between

Hydronic 4 - 2.4 kW to 4.3 kW/hr (8,200 to 14,781 BTU/hr).
 Hydronic 5 - 2.4 kW to 5 kW/hr (8,200 to 17,100 BTU/hr).

This compact coolant heater offers an affordable heating solution to many applications. The Hydronic 4/5 is ideal for pre-heating the engines of trucks, cars, off-road equipment, small trucks and boats. It features automatic heat regulation while being fuel and power efficient. Since the heater runs on fuel and 12 or 24 volt power, it is able to perform this completely independently of the vehicle engine. The unit regulates the coolant temperature between a low of 75°C (167°F) and a high of 85°C (185°F) by automatically cycling the heater between heat levels.

The Hydronic 4/5 can be operated from the vehicle cab by an on/off switch, a pre-select timer or a combination of both. Remote is optional.

A flame sensor, temperature regulating sensor and overheat sensor are among the safety features which makes the Hydronic D4/D5 a safe and dependable heating system.

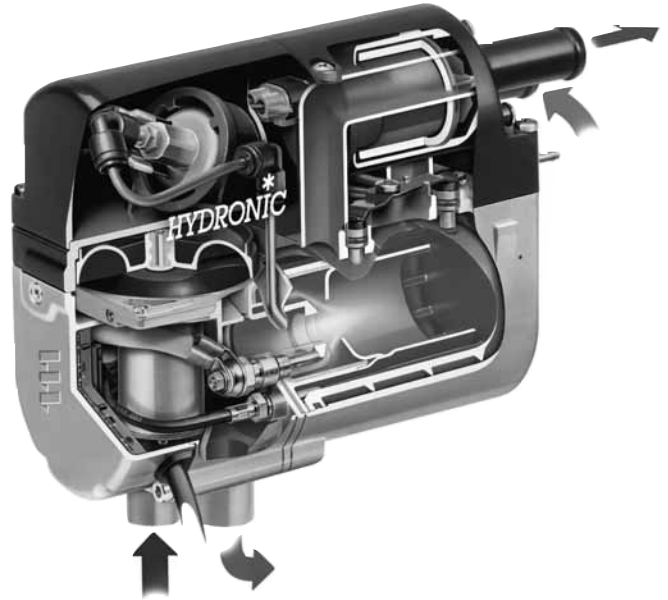

Specifications	Hydronic 4	Hydronic 5	
Heat output (±10%)	4.3 kW (14,781 BTU/hr) - High 2.4 kW (8,200 BTU/hr) - Low	5 kW (17,000 BTU/hr) - High 2.4 kW (8,200 BTU/hr) - Low	
Current draw (±10%)	4.0 amps High 1.91 amps Low	12 volt	24 volt
Fuel consumption (±10%)	0.53 l/hr (0.13 US gal/hr) High 0.27 l/hr (0.07 US gal/hr) Low	4.16 amps High 1.91 amps Low	2.08 amps High 0.95 amps Low
Operating Voltage Range			
Minimum Voltage	10.2 V	10.2 V	20.4 V
Maximum Voltage	16 V	16 V	32.0 V
Working pressure	2.5 bar (36 psi)	2.5 bar (36 psi)	
Ambient operating temperature	-40°C to +80°C (-40°F to 176°F)	-40°C to +80°C (-40°F to 176°F)	
Overheat temperature shutdown (±5%)	105°C (221°F)	105°C (221°F)	
Weight	2.9 kg. (6.4 lbs.)	2.9kg. (6.4lbs)	
Controls available - Refer to Product Catalogue			

Note: The heater is equipped with a high-voltage cutout as well as a low-voltage cutout.

Note: For specifications of gasoline heaters, please see original manual in heater packaging

Heater Components - Hydronic 4 & 5 SC versions - 12 + 24 Volt - Diesel

25 2219 05
25 2147 05
25 2257 05

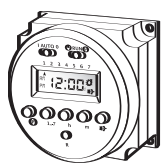
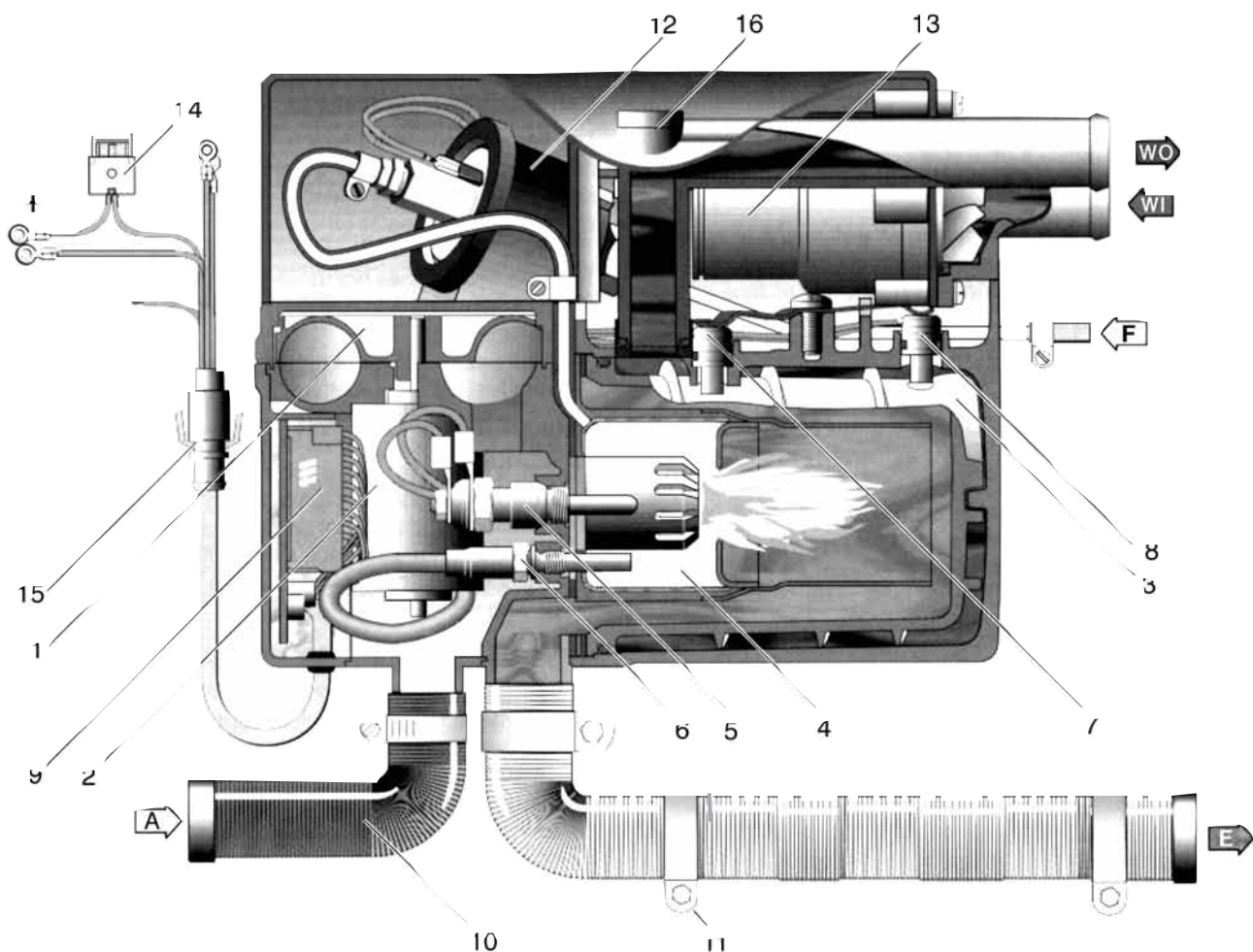

17

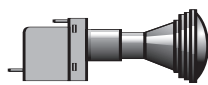

18



19

- A = Combustion air**
- E = Exhaust**
- F = Fuel supply line**
- WO = Water Outlet**
- WI = Water Inlet**

- | | |
|-------------------------------|------------------------------|
| 1 Combustion air blower wheel | 11 Exhaust tube |
| 2 Electric motor | 12 Fuel-metering pump |
| 3 Heat exchanger | 13 Coolant pump |
| 4 Combustion chamber | 14 Main fuse |
| 5 Glow pin | 15 Interface/8-pin connector |
| 6 Flame sensor | 16 Bleed screw |
| 7 Temperature sensor | 17 Programmable Timer |
| 8 Overheat temperature sensor | 18 Push/Pull switch |
| 9 Control unit | 19 7-day timer |
| 10 Combustion air tube | |

Introduction

Heater Components - Hydronic 5 S - 12 & 24 volt versions - Diesel & Gasoline versions

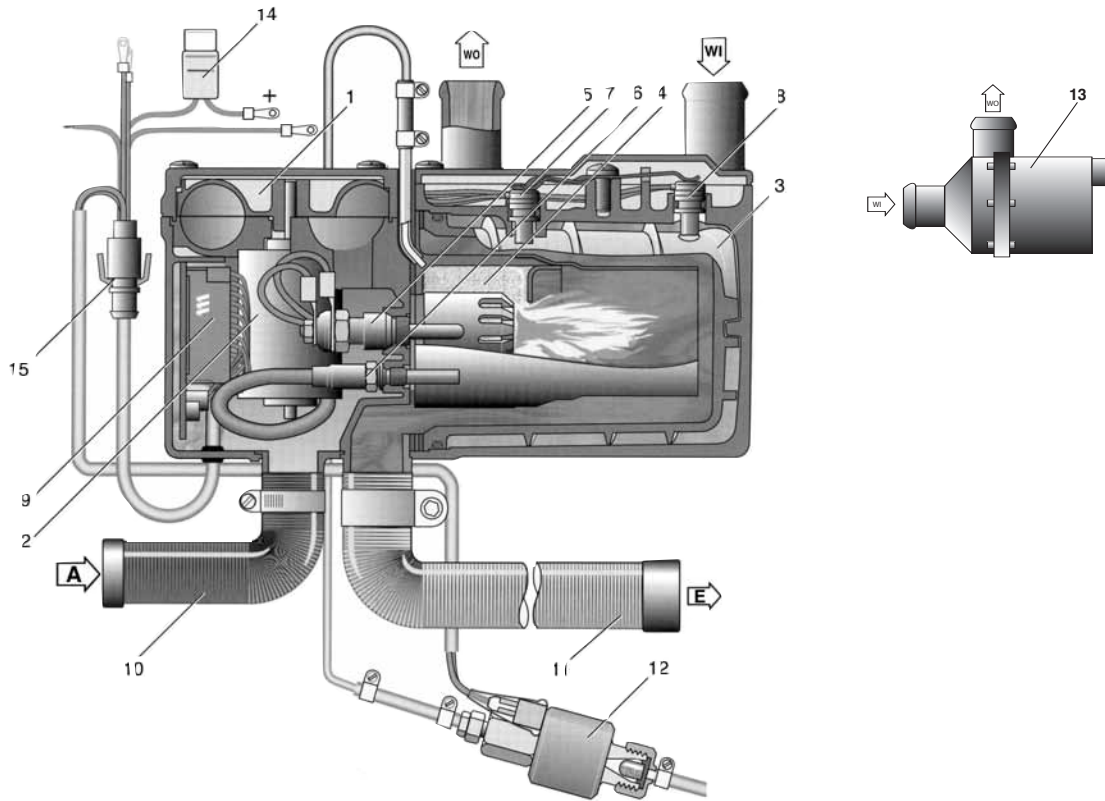

Heater Components - Hydronic 4 & 5 SC - 12 volt version - Gasoline

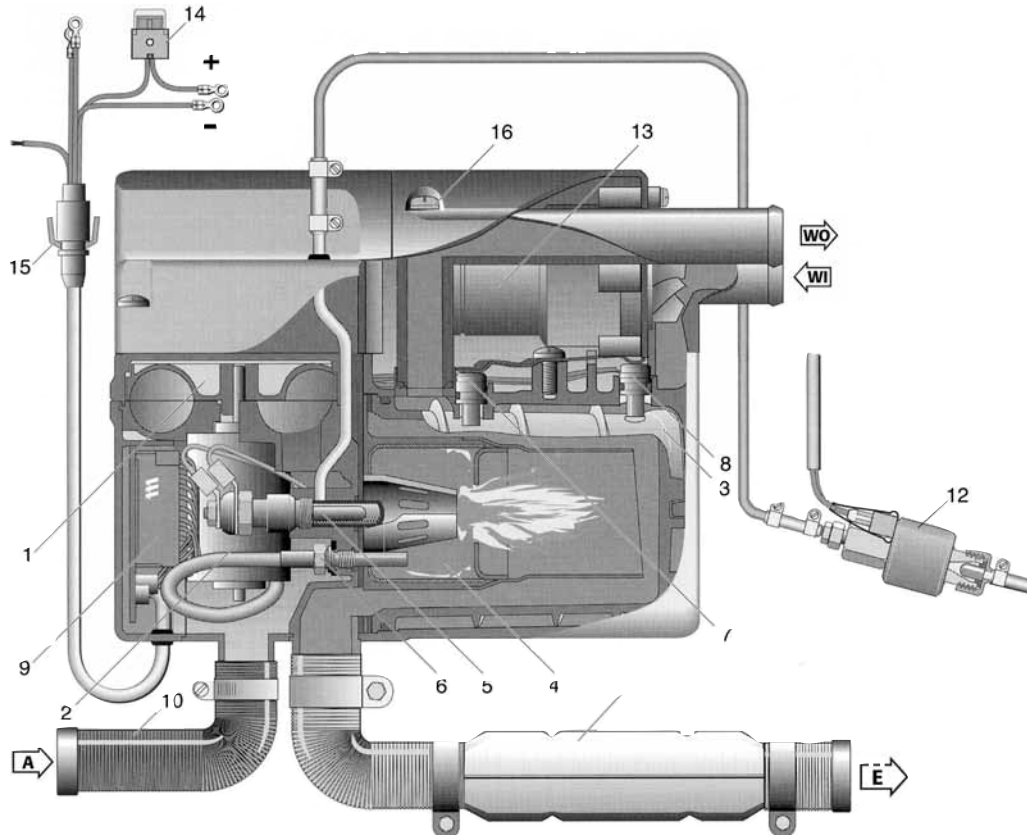

Principal Dimensions - Hydronic D4/D5 SC

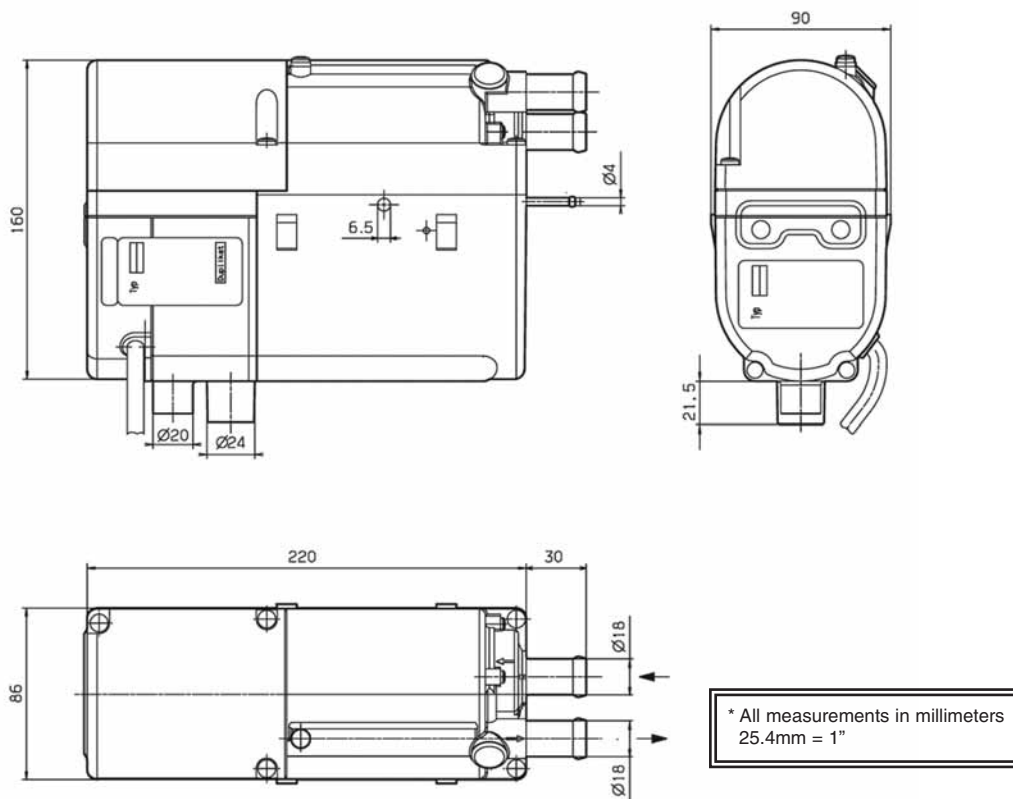

Heater Location

Always mount the heater in a protected area. Eg: storage compartment, engine compartments, step box or battery box. Espar recommends you use the boxed unit. Boxed heaters can be mounted by utilizing one of the existing brackets. See following page.

If mounting on frame rail use an optional Espar Inside frame bracket to mount to inside of frame rails. Heaters can also be mounted on a cross tray behind the cab and on top of the frame rails.

When mounting the heater adhere to the following conditions:

- Situate the heater below the normal coolant level of the engine.
- Guard against excessive road spray.
- Keep coolant hoses, fuel lines and electrical wiring as short as possible.

Caution: *Guard the heater against excessive road spray to avoid internal corrosion.*

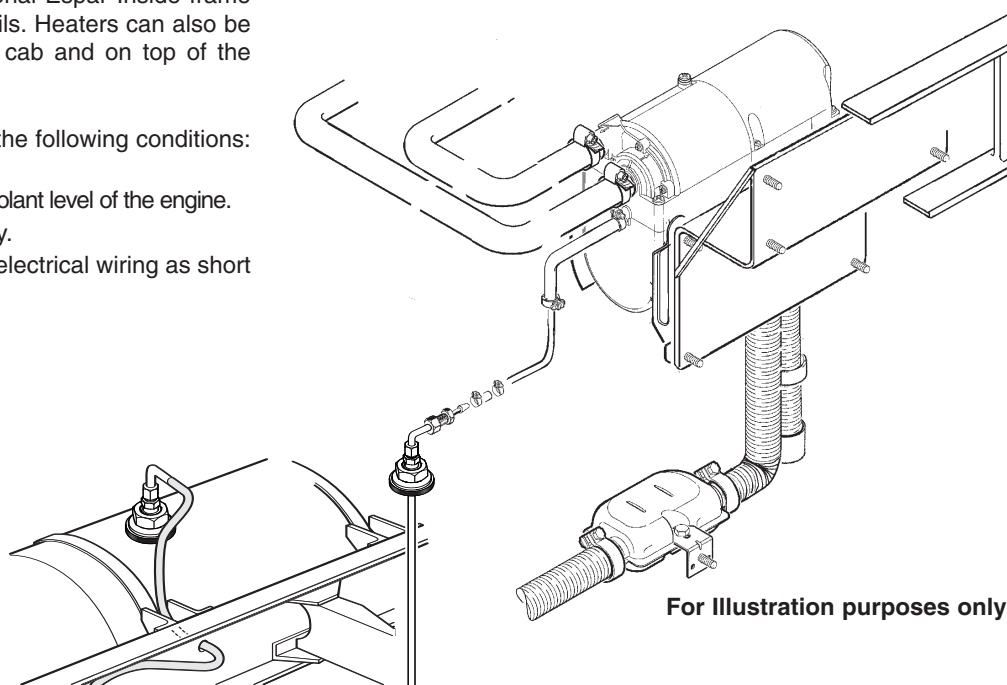

Installation Procedures

Heater Mounting

Mount the heater in the heater bracket and secure with hardware provided. If heater is not a boxed unit, mount bracket onto inside frame rail bracket. Boxed unit can also be secured to the inside frame bracket or mounted to the Cross Frame Mounting Tray.

- ① Cross Frame Mounting Tray
- ② Hydronic 4/5 box
- ③ Inside frame mounting bracket

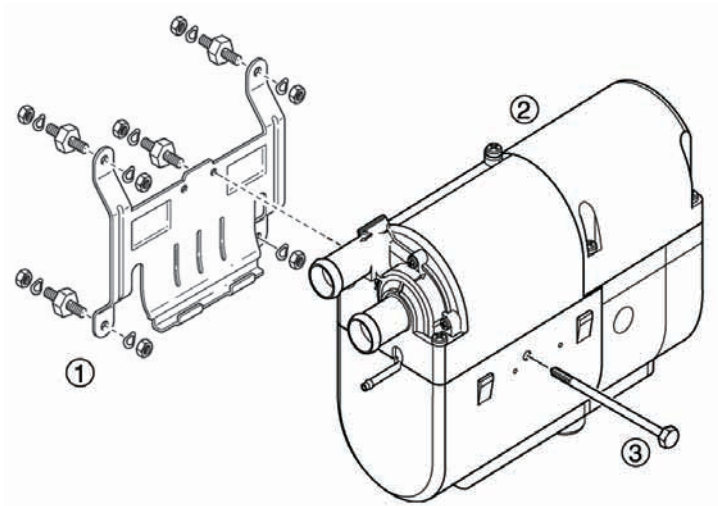
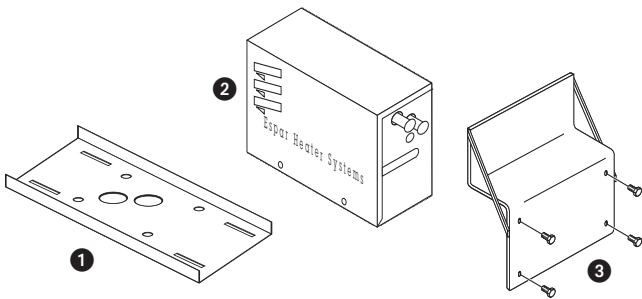

- ① Heater bracket
- ② *HYDRONIC*
- ③ Fastening screw

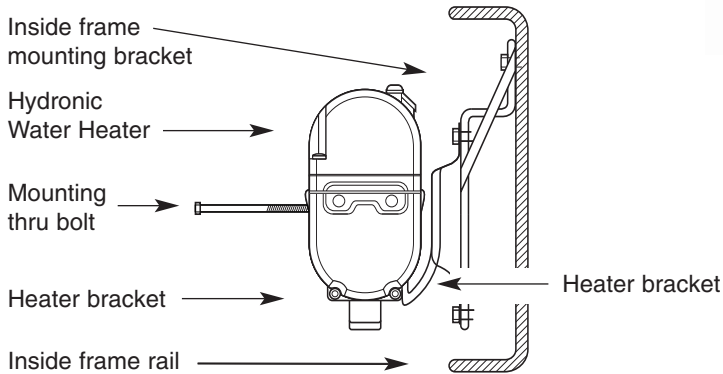

For "S" and gasoline version heaters which have external fuel metering pumps:

- Choose a protected mounting location close to the fuel pick-up pipe and heater.
- Using the bracket and rubber mount provided, install fuel pump as shown.

Note: Proper mounting angle of the fuel pump is necessary to allow any air or vapor in the fuel lines to pass through the pump rather than cause a blockage.

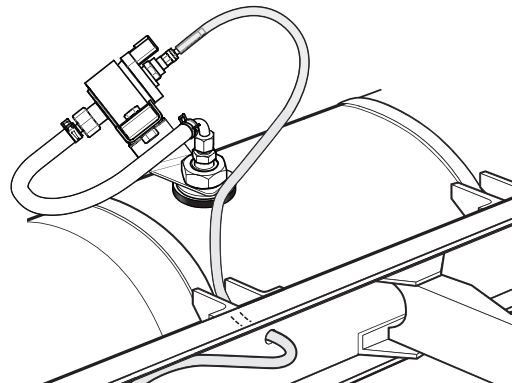
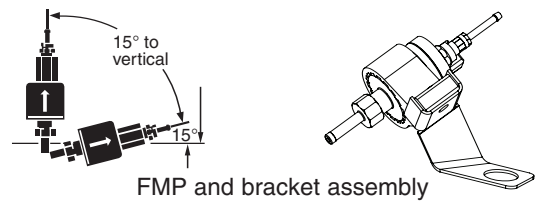

Installation Procedures

Heater Plumbing

The heater is incorporated into the engine's cooling system for engine preheating.

Engine Plumbing

Follow these guidelines and refer to engine plumbing diagram shown.

- Use existing holes in the engine block (ie. remove blanking plugs when possible). Install fittings into the block for pick-up and returns.
- If possible, use 5/8 ball shut off valves minimum to ensure the system can be isolated from the engine when not in use.
- Provide (3/4") hose barbs for hose connections.
- Use (3/4") hoses to ensure adequate coolant flow.
- Keep the pick up and return points as far apart as possible to ensure good heat distribution.
- Take the coolant from a low point on the engine to reduce aeration in the system.
- Ensure proper direction of coolant flow by taking coolant from a high pressure point in the engine and returning it to a low pressure point. (ie. pickup from back of block and return to the suction side of the engine's water pump).
- Ensure adequate flow rate through the heater by comparing the incoming and outgoing coolant temperatures while the heater is running. If the rise in temperature exceeds 10°C (18°F), coolant flow must be increased by modifying the plumbing.
- Ensure the heater and water pump are installed as low as possible to allow the purging of air. Bleed system via radiator or bleed screw located on heater.

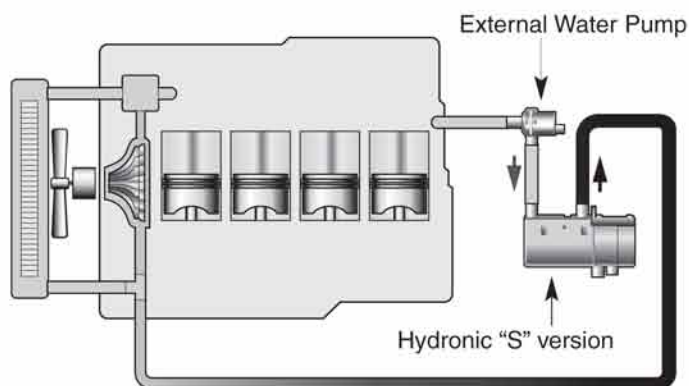
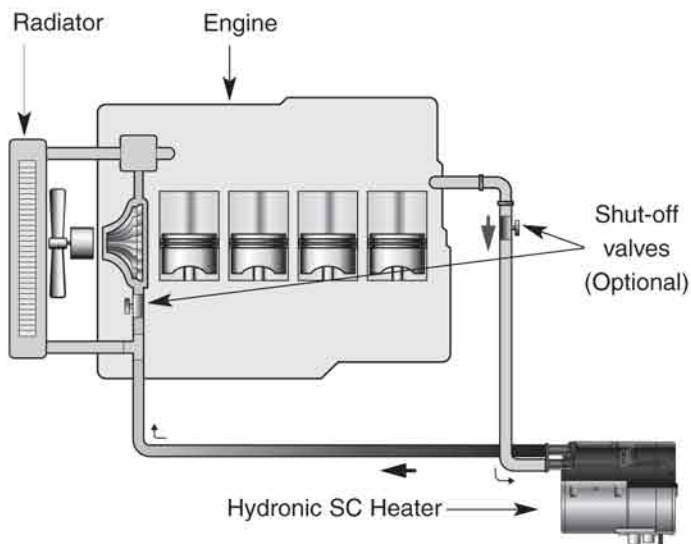

Optional Outlets Available in 18mm and 20mm

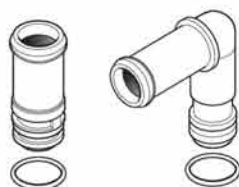

See Product Catalogue

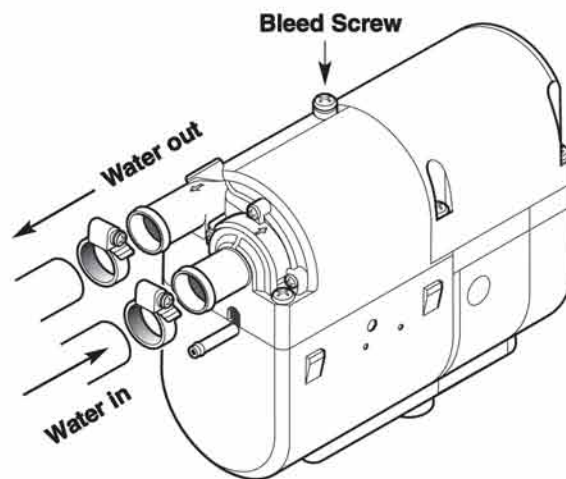

Caution: The coolant must contain a minimum of 10% antifreeze at all times as a protection against corrosion. Fresh water will corrode internal heater parts.

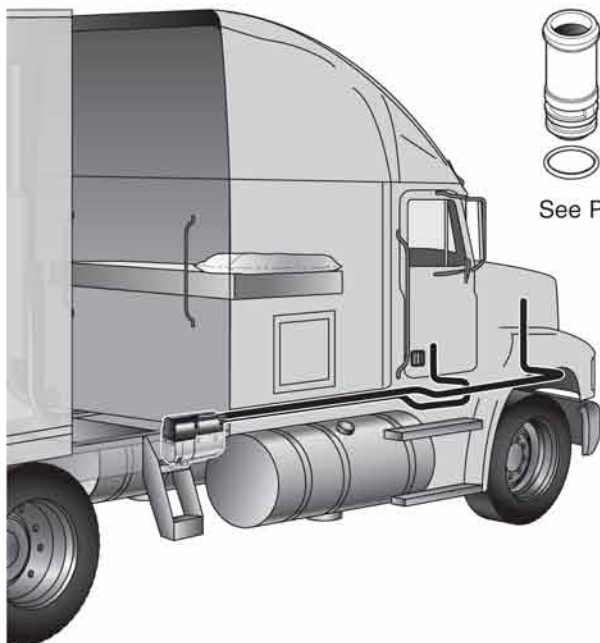

Installation Procedures

Fuel System

Some Hydronic water heaters (2219) typically have the fuel metering pump mounted inside the unit. This is to reduce installation time and to protect the pump from corrosion. Some versions have an external fuel metering pump. Refer to graphics for connections and specifications. All parts necessary to do the installation are included in the kit as shown.

Note: For 25 2219 and similar "SC" Heaters:
 Fuel line limits must not be exceeded.
 Ensure that the following conditions are met.
 Hydronic heater must be within a height of 76cm (2'6") from the bottom of the fuel pick-up pipe.
 Fuel-metering pump must be within a total distance of 200 cm (6'6") from the fuel pick-up pipe.
 If the above conditions cannot be met, a heater with external fuel metering pump must be used.

Fuel System Tolerances

1. Fuel Pick-Up Pipe
2. Fuel Pipe Reducer
3. 9mm Clamp
4. 3.5mm Rubber Connector
5. 2.0mm White Plastic Fuel Line
6. Fuel Metering Pump
7. 1.5m White Plastic Fuel Line

Fuel Line

- Route fuel lines from the fuel pick-up pipe to the heater.
- Use only fuel lines provided.
- Other sizes or types of fuel lines may inhibit proper fuel flow.
- Make proper butt joints using clamps and connector pieces as shown.
- Use a sharp utility knife to cut plastic fuel lines to avoid fuel line pinching.

Note: Butt joints and clamps on all connections.

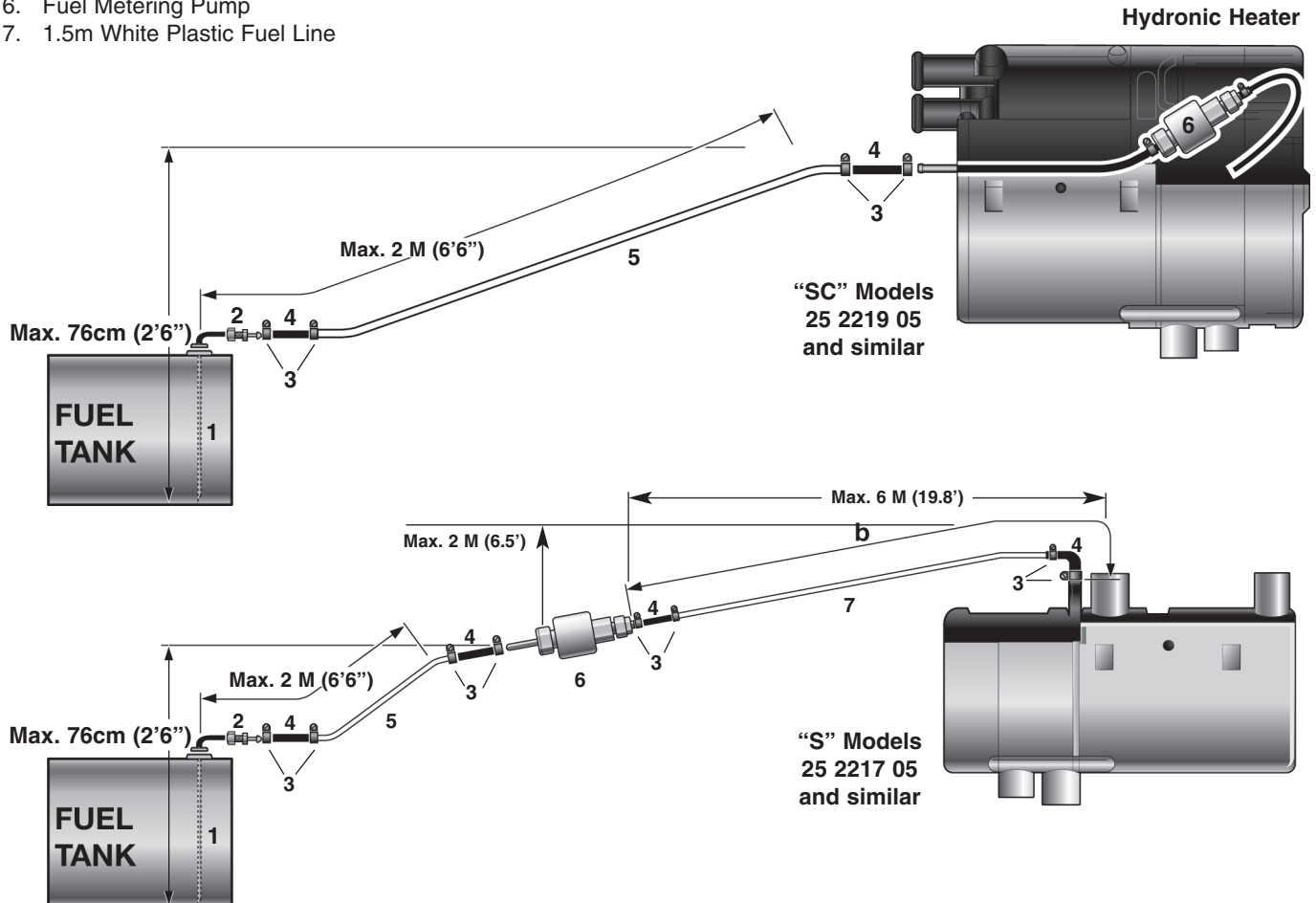
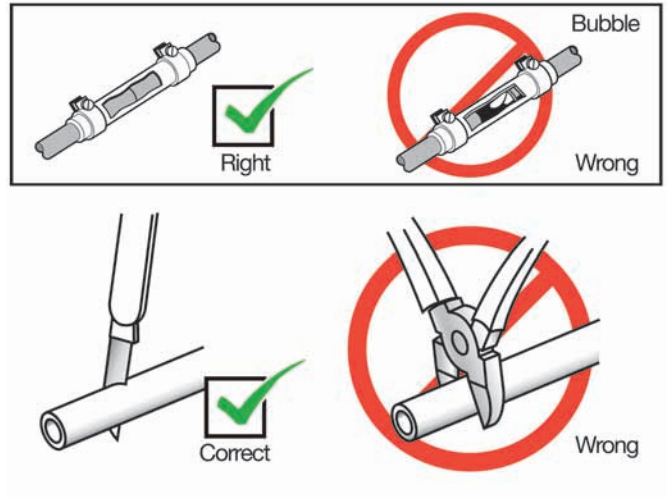

Installation Procedures

Fuel Pick-Up Pipe Installation (Drill Option)

- Choose a protected mounting location close to the pump and heater. A spare fuel sender gauge plate provides an ideal mounting location. If one is not available...
- Drill mounting holes in tank to accommodate pick-up pipe as shown.
- Tighten Ferrule nut to pick-up pipe at desired height.
- Cut the fuel pick-up pipe to length. Allow 2-2.5" from bottom of tank.
- Mount the fuel pick-up pipe as shown.
- Lower the fuel pick-up pipe (with reinforcing washer) into the tank using the slot created by the two 0.6cm (1/4") holes.
- Lift the assembly into position through the 2.5cm (1") hole.
- Assemble the rubber washer, metal cup washer and nut.

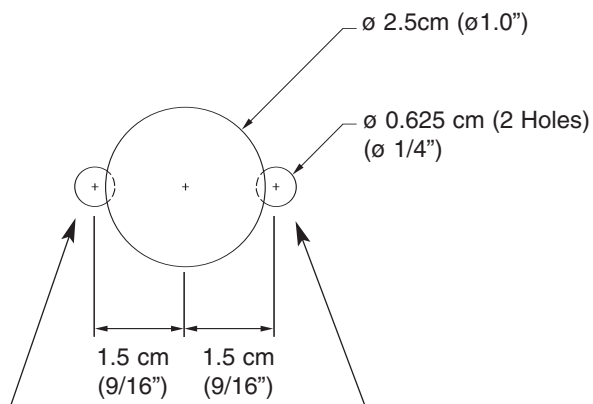
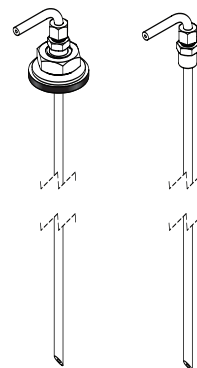
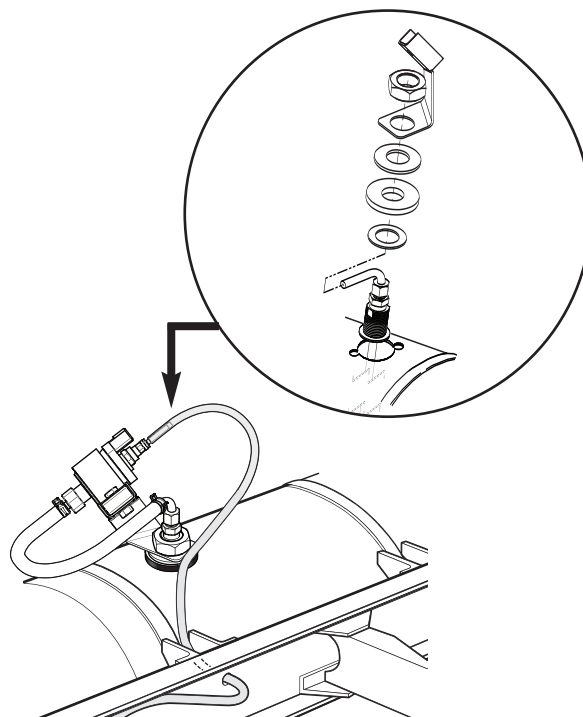

Note: Drill the two (1/4") holes first.

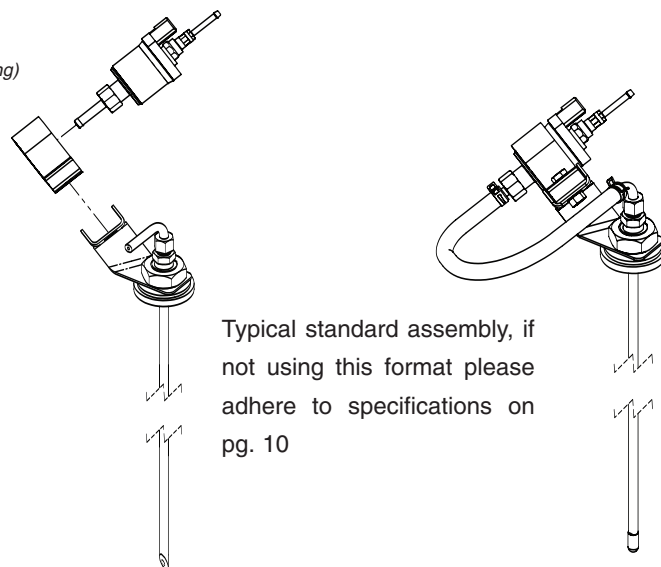
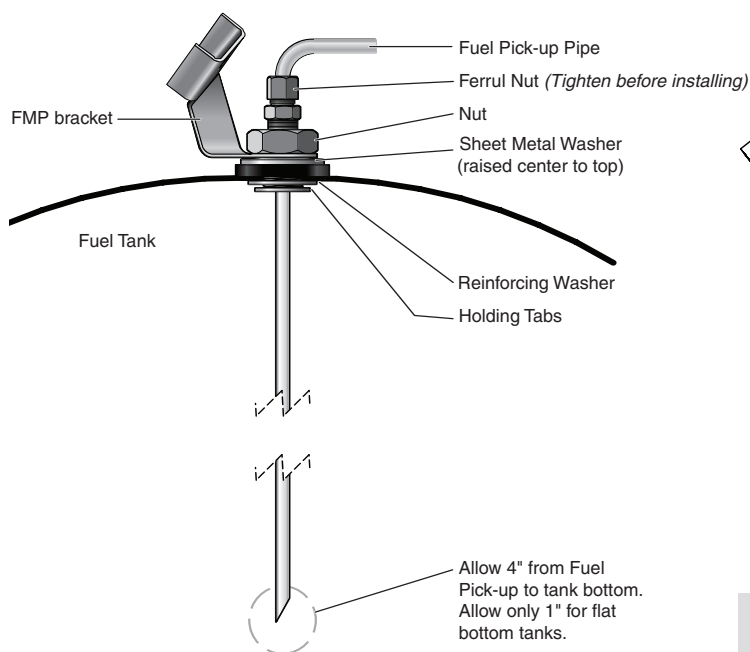

Note: NPT fittings are available in various sizes (Refer to ESPAR Product Catalogue).

Installation Procedures

Electrical Connections

All parts needed are included with the kit. (*) indicates external mounted fuel and or water pump versions of Hydronics.

- A. Main Heater Harness**.....
 - Connects switch and power harness to the heater harness. (* in some cases power to fuel metering pump).
- B. Power Harness**.....
 - 2 core harness (red, brown).
 - Connect red wire to fuse link and terminal.
 - Attach ring terminal to vehicle battery (+).
 - Connect brown wire to vehicle battery (-) using ring terminal provided.
 - 20 amp fuse - 12V.
 - 15 amp fuse - 24V.
- C. Switch Harness**.....
 - 4 core harness (red/yellow, brown, yellow, blue/white).
 - Run to location of control option. Make terminal connections at control option. Espar has 2 available switches see control option instructions on following pages.
- D. * Fuel Metering Pump Harness**.....
 - 2 core harness (green, green) or (green, brown).
 - Connect to fuel metering pump using terminals and protective seals + connector block (no polarity required).
- E. * Water Pump Harness**.....
 - 2 core harness (black, brown).

Hydronic Heaters

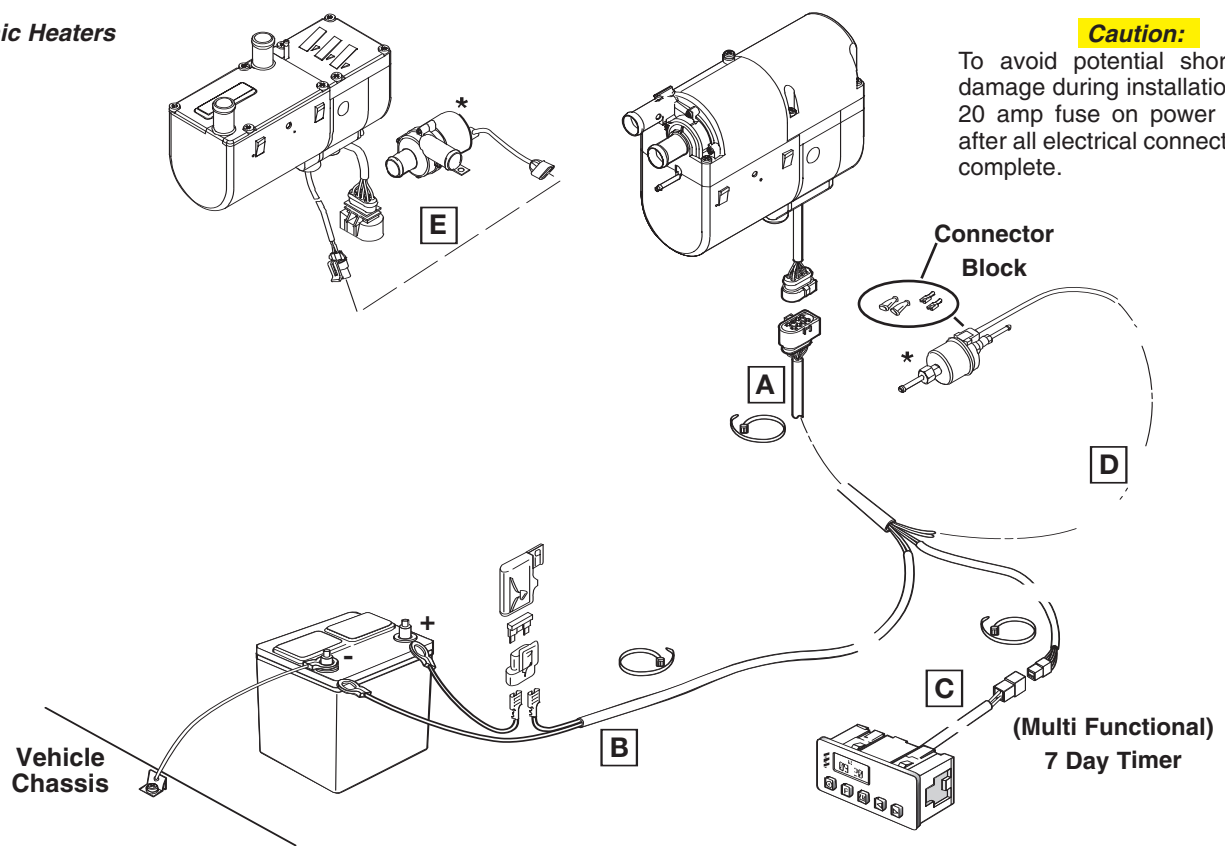

Important:
 Negative battery terminal must always be grounded.
 If a vehicle is equipped with switch on negative battery wire, install additional 20 A fuse in negative wire of heater's harness.

Note: All harnesses should be cut to length. All exposed electrical connections should be coated with protective grease.
Installation Note: Wire must be inserted into fuse holder prior to terminating.



Installation Procedures

Exhaust Connection

A 24mm flexible tube exhaust pipe is required for the exhaust. An exhaust clamp is used to secure the exhaust to the heater. Connect the exhaust as follows:

- Connect the exhaust pipe to the exhaust port on the heater and attach with clamp provided.
- Run exhaust to an open area to the rear or side of the vehicle so that fumes can not build up and enter the passenger compartment or the heater combustion air intake.
- Install exhaust pipe with a slight slope or drill a small hole in the lowest point to allow water to run out. Any restriction in exhaust will cause operational problems.
- Route the exhaust pipe from the heater using “p” clamps provided.

Caution: Run exhaust so that it cannot be plugged by dirt, water or snow. Ensure the outlet does not face into the vehicle slip stream.

Intake Connection

Combustion air must be drawn in from the outside. The combustion air opening must be kept free at all times.

- Connect the air intake pipe to the intake port on the heater and secure with clamp provided.

Caution: Do not install the intake opening facing the vehicle slipstream. Ensure that the opening cannot become clogged with dirt or snow and that any water entering the intake can drain away.

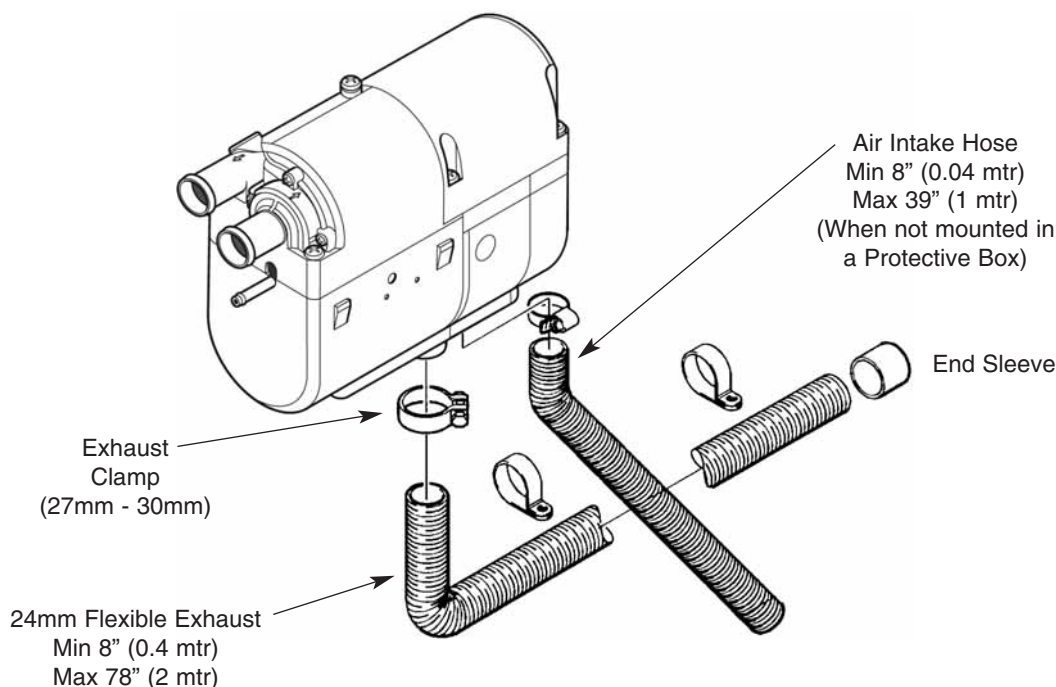

Warning - Fire Hazard

The exhaust is hot, keep a minimum of 5cm (2") clearance from any heat sensitive material. Route exhaust so that the exhaust fumes cannot enter the passenger compartment.

Warning - Asphyxiation Hazard

Route exhaust beyond the skirt of the cab and outside of the frame area. Failure to comply with this warning could result in Carbon Monoxide Poisoning.

Installation Procedures

Control Options

A Programmable Timer, Push/Pull switch or a Multifunction (7 Day Timer) are available.

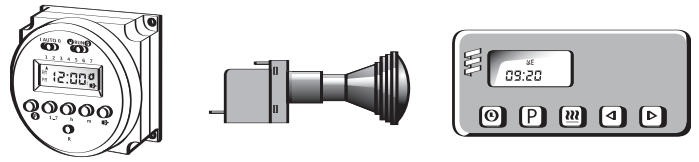

Multifunction

The multifunction is capable of multiple start functions within a 7 day period. Other functions include current time display and AM automatic heater numeric fault code. Display refer to instructions provided with timer for setting options.

- Mount timer and bracket in a suitable location.
- Connect the switch harness to the connector at the heater and run the harness to the control location.
- Cut harness to length at the control and install terminals.
- Connect switch harness to timer as shown below.
- Refer to timer instructions for other wiring options.

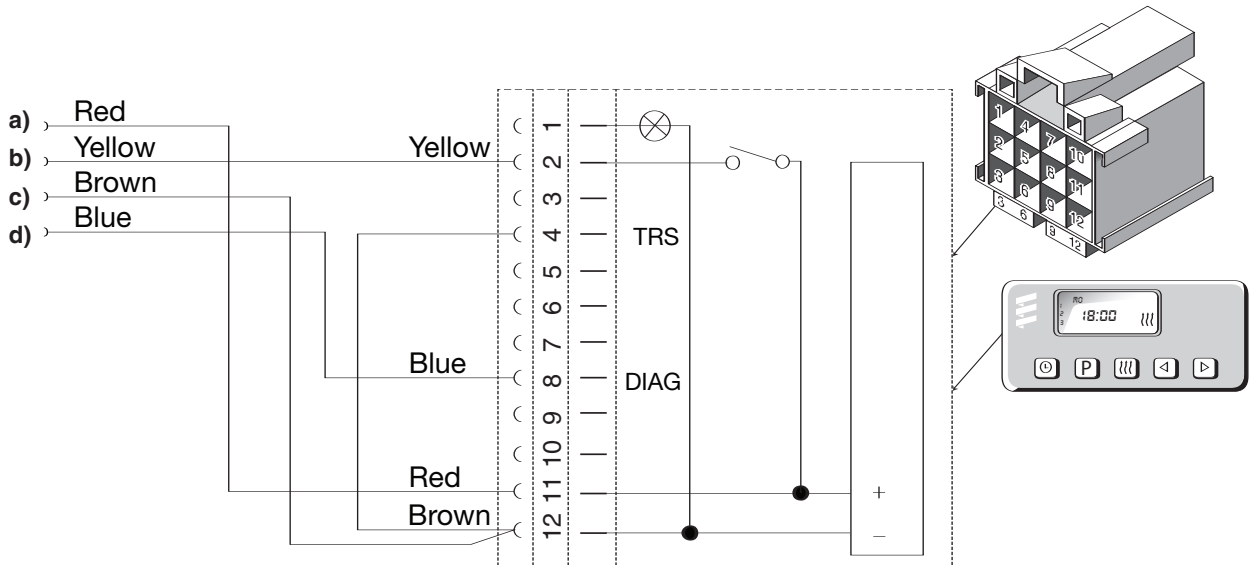
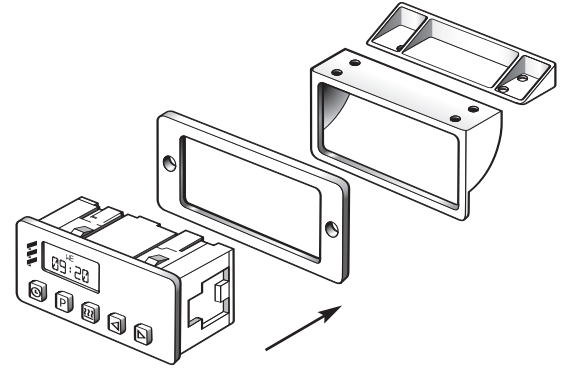

- a) Power from battery “+”.
- b) Switch control to the heater.
- c) Power from battery “-”.
- d) Diagnostic from heater.

Option #1: Dash lights to timer - connect wire between dash lights circuit and timer at terminal #1.

Option #2: Operate heater continuously - connect wire from ignition circuit to terminal #10. See also multifunction (7 day) timer in instructions.

Heater Operation

Push/Pull Switch

- Mount switch in a location where it is easily accessible.
- Mount using hardware supplied.
- Connect the switch harness to the connector at the heater and run the harness to the switch location.
- Cut harness to length at the switch and install terminals.
- Connect wiring as shown.

Control Wiring Push/Pull Switch

Brown- 31	Power from battery “-”
Red- K(15)	Power from battery “+”
Yellow-15(K)	Switch control to the heater
Blue/White	Diagnostic from heater (disregard - tape end and tie off to the side)

Note: Wired as above the switch light glows when pulled out and is off when pushed in.

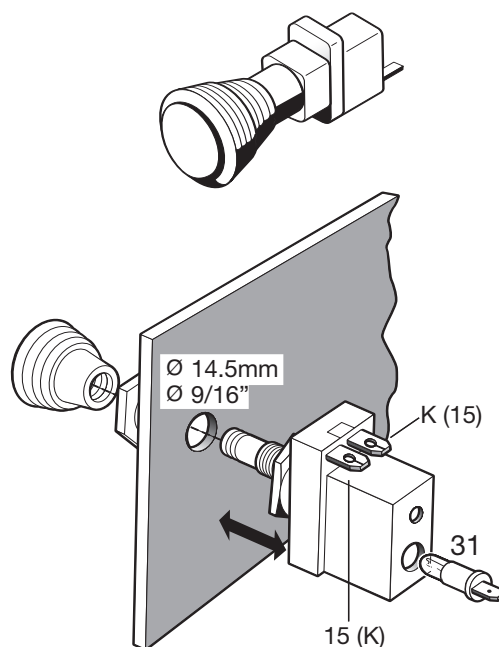

Heater Operation

Pre-Start Procedures

Upon completion of installation prepare the heater as follows:

- Check all fuel, electrical and plumbing connections.
- Refill the engine coolant.
- Bleed air from the coolant system by loosening the bleed screw on top of the heater to allow air to escape.
- Loosen rad cap and run engine to allow air to be purged.
- Top up engine coolant.

Start Up

Once switched on the following sequence occurs:

- Control unit does a systems check (flame sensor, glow pin, motors, temperature sensor, safety thermal sensor and various other control unit checks).
- Water pump starts circulating coolant fluid.
- Combustion air blower comes on.
- Glow pin begins to preheat 20-50 secs.
- Metering pump starts and combustion air blower speeds up gradually.
- Once ignition takes place the flame sensor alerts the control unit and the control unit shuts off the glow pin (ignition time: 1.5 - 2 minutes).

Note: If the heater fails to start the first time it will automatically attempt a second start. If unsuccessful, the heater will shut down completely.

Note: On initial start up the heater may require several start attempts to self prime the fuel system.

Running

Once ignition is successful the following operations take place:

- Heater runs in high heat mode and the temperature is monitored at the heat exchanger.
- Once coolant reaches 80°C (176°F) the heater automatically switches to low heat mode and continues to run.
- If coolant temperature drops to 75°C (167°F) the heater will automatically switch back to high heat mode.
- If the coolant temperature continues to rise, the heater will automatically switch off once temperature reaches 85°C (185°F).
- The water pump will continue to circulate coolant to allow the heater to monitor engine temperature.
- The heater will automatically re-start once coolant temperature reaches 75°C (167°F).
- The heater continues to run as described above until it is switched off, either manually, automatically by a timer or heater malfunction shutdown.

Note: If the heater should shut down due to flame out while in running mode, it will automatically attempt one restart. If successful, it will continue to run. If not, it will shut down completely with a cool-down cycle.

Note: During operation the heater continually senses the input voltage from the batteries. If the input voltage drops to approximately 10.5 volts or rises above 16 volts the heater will automatically shut down with a cool-down cycle, and display a fault code when using a multifunction timer.

Heater Operation

Switching Off

- When the heater is switched off, manually or automatically, it starts a controlled cool down cycle.
- The fuel metering pump stops delivering fuel and the flame goes out.
- The combustion air blower and water pump continue to run for 3 minutes to cool down.
- The heater shuts off.

Safety Equipment

The control unit, temperature sensor, overheat sensor and flame sensor continually monitor heater functions and will shut down the heater in case of a malfunction.

- The control unit ensures electrical circuits (fuel pump, combustion air blower etc.) are complete prior to starting the heater.
- If the heater fails to ignite within 90 seconds of the fuel pump being started, the starting procedure will be repeated. If the heater again fails to ignite after 90 seconds of fuel being pumped, a “no start safety shutdown” follows. (Fault #52)
- If the heater flames out during operation, the heater automatically attempts to restart. If the heater fails to ignite within 90 seconds of fuel delivery, the heater will turn off the fuel pump and complete a cool down and display a F052 code. After troubleshooting the problem the heater can be started again by switching the heater off and then back on again.
- Overheating due to lack of water, a restriction or a poorly bled coolant system results in the overheat shutdown (F012). Fuel delivery will cease and an “overheat shut down” follows. If heater overheats 10 consecutive times, a lockout on the control unit will occur. To unlock the control unit you will need to use the Fault Code Retrieval Device. See following pages for self diagnostics.
- If at any time the voltage drops below 10.5V for 20 seconds, or rises above 16.0V for 20 seconds the heater will shut down and display the associated Fault Code.







Warning:

The heater must be switched off while any fuel tank on the vehicle is being filled. The heater must not be operated in garages or enclosed areas.



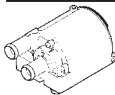
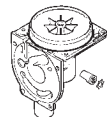

Heater Operation

Operating Mode	STARTING PHASE					RUNNING PHASE	SHUT DOWN PHASE		
	System Check	Pre-heat	Ignition Attempt	Pre-heat 2nd. attempt	Ignition Attempt 2nd. attempt	Controlled Heating	After Glow	Cool Down	Off or Stand by
 Water Pump	Off	On	On	On	On	On	On	On	Off On: if in stand by
 Blower	On Momentarily	On	On	Off	On	On	On	On	Off
 Glow Pin	Off	On	On	On	On	Off	On	Off	Off
 Fuel Pump	Off	Off	On	Off	On	On	Off	Off	Off
Time 	1- 3 sec.	40 sec.	Up to 80 sec.	40 sec. If Required	Up to 80 sec.	High/Low Operation until switched off manually or automatically	20 sec.	2.5 min.	

Note: During the controlled heating cycle, if the coolant temperature exceeds 86°C(187°F) the heater will cycle off. Heater will automatically restart in high mode once coolant temperature reaches 75°C(167°F)

Notes:

Heater Diagnostics

Hydronic D4 SC 12 Volt
Model 25 2096 05

Wiring Harness P/N:
20 2900 70 05 03

- 1.1 Blower motor
- 1.2 Glow pin
- 1.5 Overheat sensor
- 1.12 Flame sensor
- 1.13 Temperature sensor
- 2.1 Control unit
- 2.12 Water Pump
- 2.2 Fuel metering pump
- 2.7 20 amp main fuse
- 3.12 Push/Pull switch
- 3.2.9 7 day timer
- 5.1 Battery

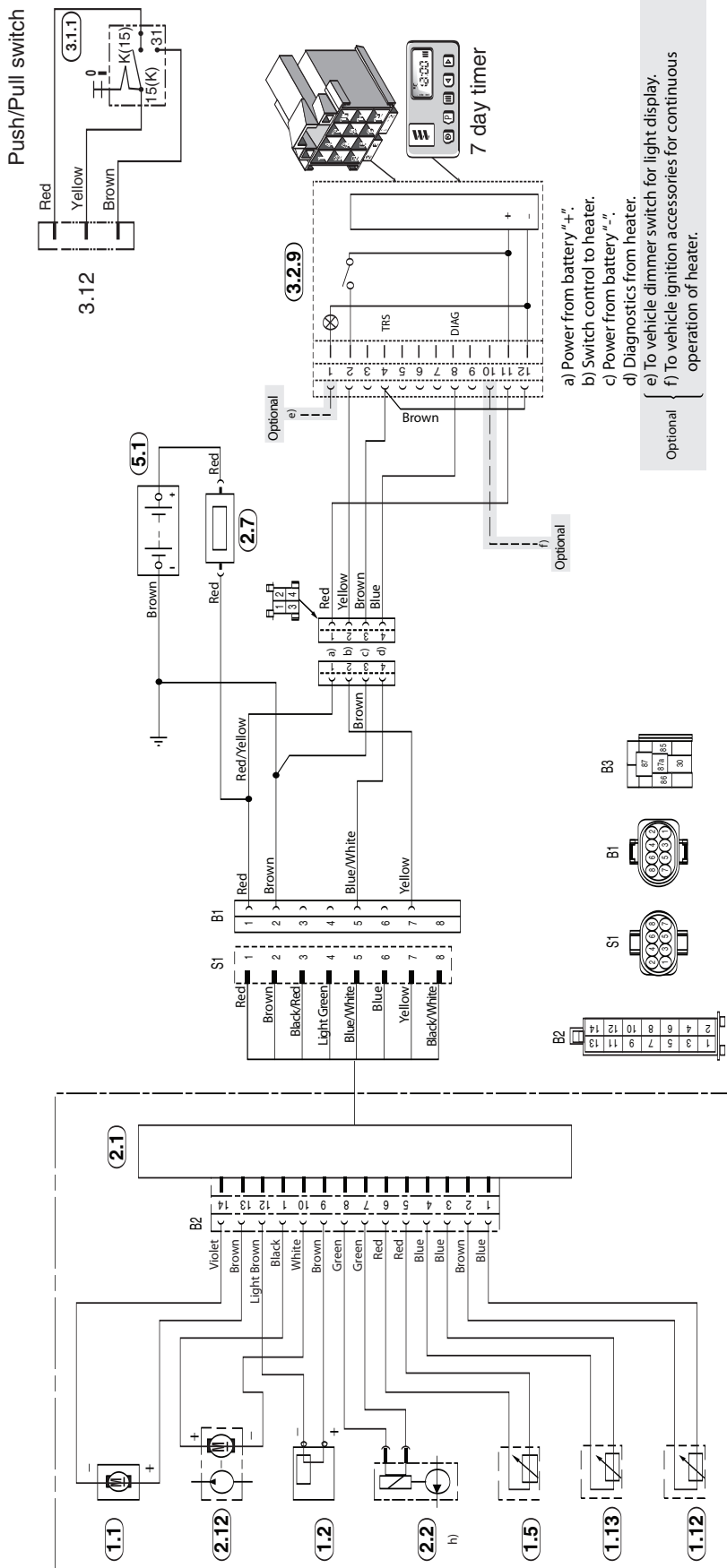

Heater Diagnostics

Hydronic D5 SC 12 Volt
Model 25 1920 05

Wiring Harness P/N:
20 2900 70 04 01

- 1.1 Blower motor
- 1.2 Glow pin
- 1.5 Overheat sensor
- 1.12 Flame sensor
- 1.13 Temperature sensor
- 2.1 Control unit
- 2.12 Water Pump
- 2.2 Fuel metering pump
- 2.5.8 Blower lock out resistor
- 2.7 20 amp main fuse
- 3.12 Push/Pull switch
- 3.2.9 7 day timer
- 5.1 Battery

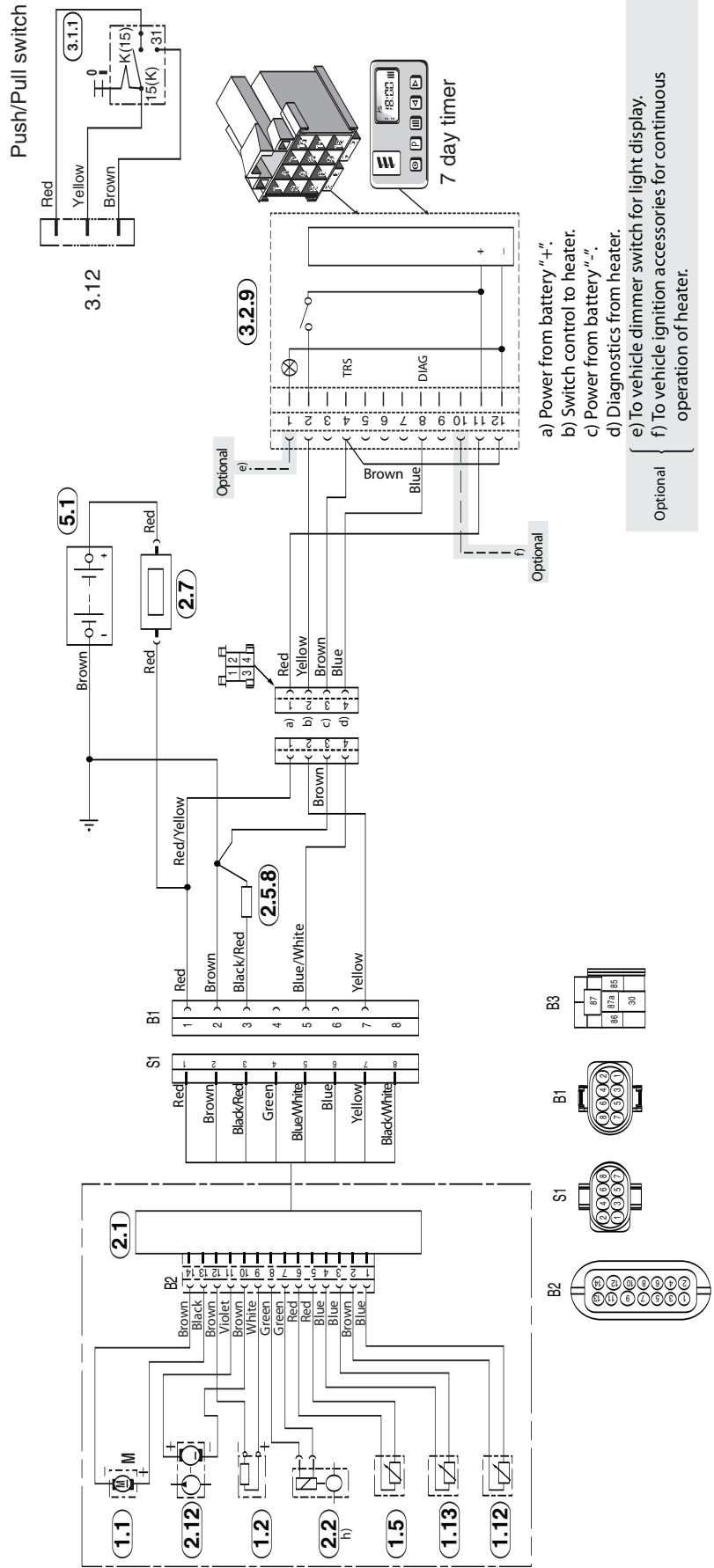

Heater Diagnostics

Hydronic D5 SC 12 Volt

Model 25 2098 05

25 2219 05

25 2257 05

Wiring Harness P/N:

20 2900 70 05 03

Internal FMP

No Blower Relay

- 1.1 Blower motor
- 1.2 Glow pin
- 1.5 Overheat sensor
- 1.12 Flame sensor
- 1.13 Temperature sensor
- 2.1 Control unit
- 2.12 Water Pump
- 2.2 Fuel metering pump
- 2.7 20 amp/12V main fuse
- 2.7 15 amp/24V main fuse
- 2.7.1 5 amp fuse
- 3.12 Push/Pull switch
- 3.2.9 7 day timer
- 5.1 Battery

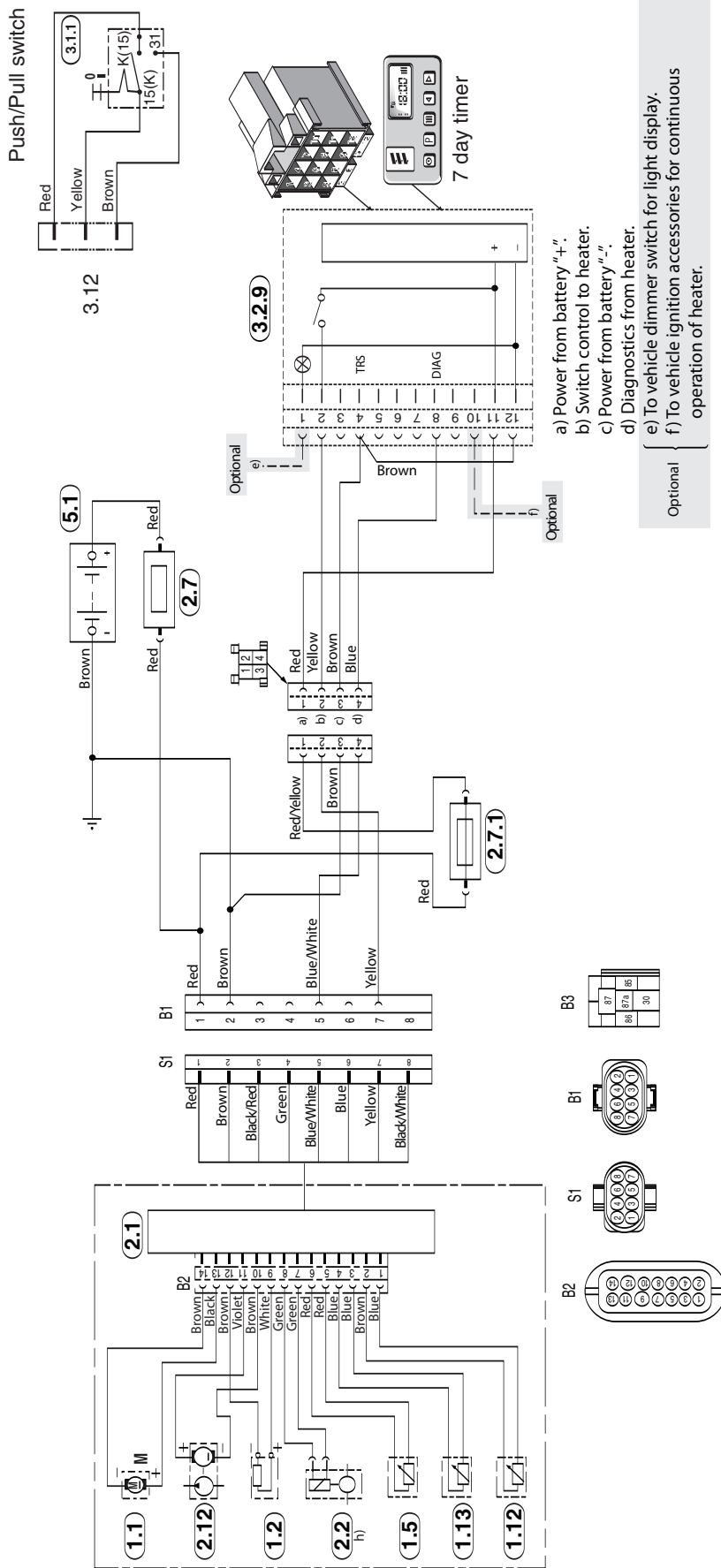

Heater Diagnostics

Hydronic D5 SC 24 Volt

Model 25 2147 05

Wiring Harness P/N:

20 2900 70 20 13

External FMP

No Blower Relay

Also applicable to:

Hydronic 4 & 5 SC 12 volt

Gasoline versions

Model 20 1820 05

Model 20 1824 05

Model 25 2325 05

- 1.1 Blower motor
- 1.2 Glow pin
- 1.5 Overheat sensor
- 1.12 Flame sensor
- 1.13 Temperature sensor
- 2.1 Control unit
- 2.12 Water Pump
- 2.2 Fuel metering pump
- 2.7 20 amp/12V main fuse
- 2.7.1 15 amp/24V main fuse
- 2.7.1 5 amp fuse
- 3.12 Push/Pull switch
- 3.2.9 7 day timer
- 5.1 Battery

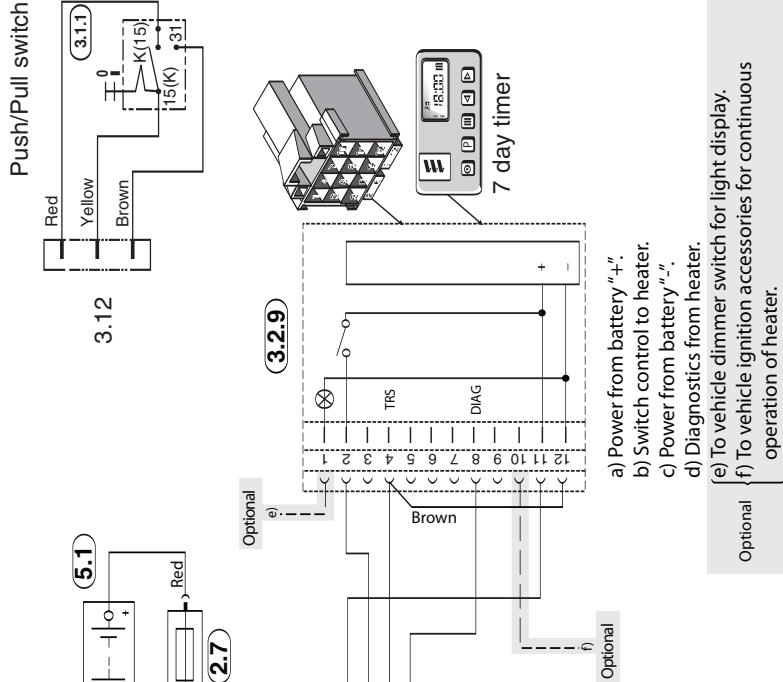
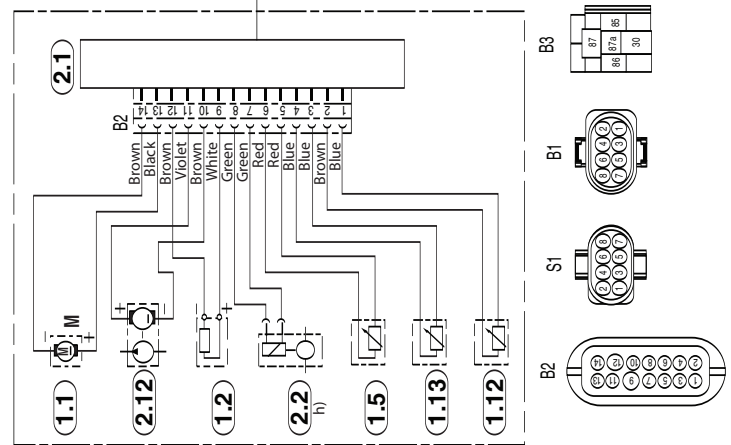

- a) Power from battery "+".
- b) Switch control to heater.
- c) Power from battery "-".
- d) Diagnostics from heater.
- e) To vehicle dimmer switch for light display.
- f) To vehicle ignition accessories for continuous operation of heater.

Optional



Heater Diagnostics

Hydronic 5 S - 12 & 24 volt versions

Diesel & Gasoline versions

Model 20 1793 05	12 volt
Model 20 1819 05	12 volt
Model 25 2146 05	24 volt
Model 25 2217 05	12 volt
Model 25 2218 05	24 volt
Model 25 2100 05	12 volt

Wiring Harness P/N:

12V 20 2900 70 05 07

24V 20 2900 70 05 08

- 1.1 Blower motor
- 1.2 Glow pin
- 1.5 Overheat sensor
- 1.12 Flame sensor
- 1.13 Temperature sensor
- 2.1 Control unit
- 2.12 Water Pump
- 2.2 Fuel metering pump
- 2.7 20 amp/12V main fuse
- 2.7.1 15 amp/24V main fuse
- 2.7.1 5 amp fuse
- 3.12 Push/Pull switch
- 3.2.9 7 day timer
- 5.1 Battery

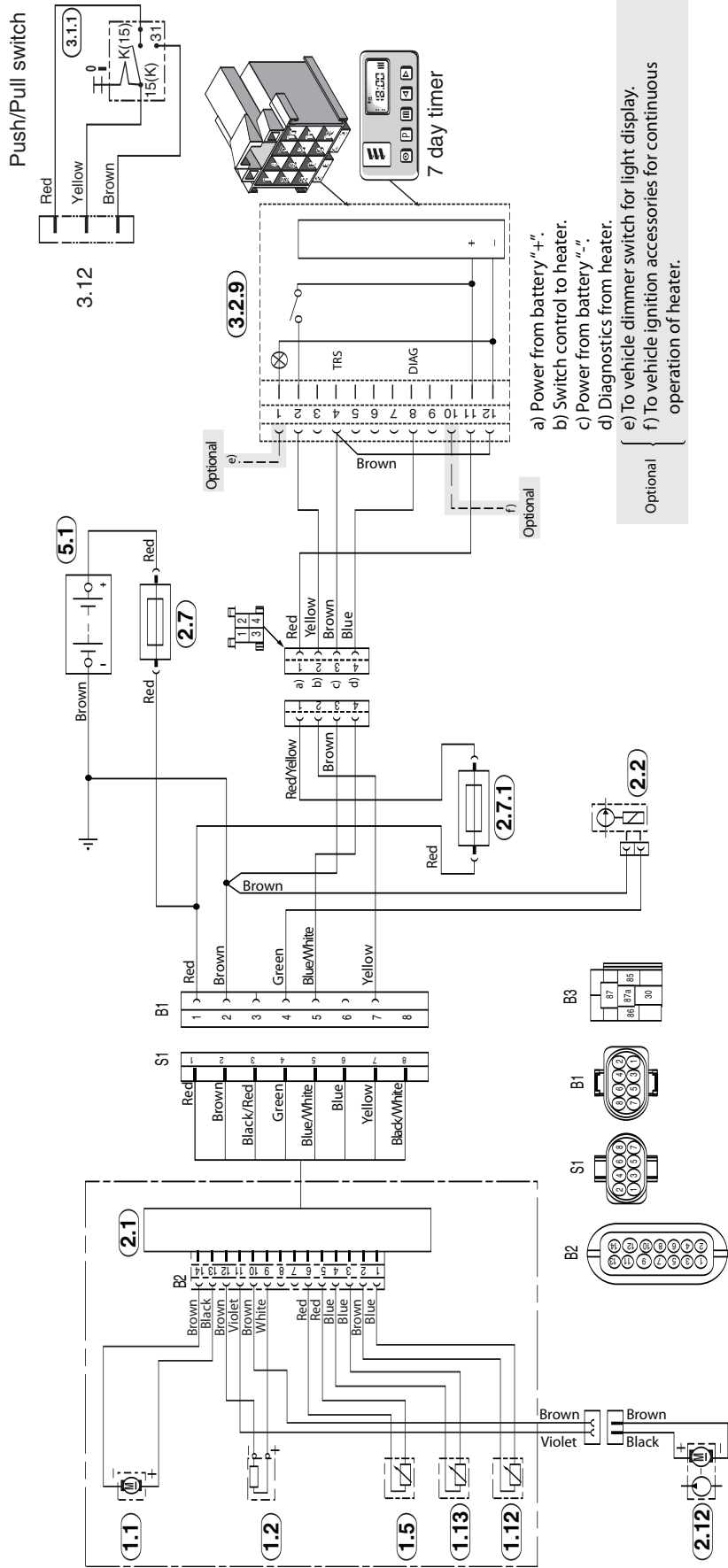

Periodic Maintenance

- Check coolant hoses, clamps, and make sure all valves are open. Maintain the engine manufacturers recommended coolant level and ensure that the heater is properly bled after service on or involving the coolant system.
- Visual check of all fuel lines for leaks. Check and if necessary replace fuel filter inserts.
- Visual check of electrical lines and connections for corrosion.
- Run your heater at least once a month during the year (for a minimum of 15 minutes).
- Maintain your batteries and all electrical connections in good condition. With insufficient power the heater will not start.

Low

and high voltage cutouts will shut the heater down automatically.

- Use fuel suitable for the climate (see engine manufacturers recommendations). Blending used engine oil with diesel fuel is NOT permitted.
- Check the glow pin and replace if necessary.

Troubleshooting

Basic Troubleshooting

In the event of failure there are several items which should be checked first before any major troubleshooting is done.

Check:

- Circuit breakers and fuses.
- Electrical lines and connections.
- For interference in combustion air and exhaust pipes.
- That there is fuel in the tank.
- Battery voltage.



Self Diagnostics

The heater is equipped with self diagnostic capability. You can retrieve information on the heaters last 5 faults using the Espar multifunction timer or Espar's Fault Code Retrieval Device.

Multifunction

Espar's multifunction timer has a fault code retrieval device built into the unit. This function automatically activates if the heater is experiencing problems.

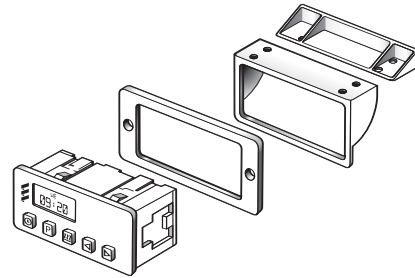

- Fault codes appear on the LCD display screen.
- Codes can then be translated from the charts on the following pages.

Fault Code Retrieval Device

Equipment Face and Controls

Symbols seen on the display face are as follows:



AF Actual fault.

F1-F5 Up to five stored faults can be accessed. The AF and F1 are the same number.



This sign is displayed when the heater is in operation.

DIAG The word (Diagnostic) will come on when the diagnostic number is requested.

000 Three digit diagnostic fault code number.

Instructions:

- Connect as shown on following page.
- Switch the fault code retrieval device on and wait 10 seconds.
- Press the "D" button.
- Wait 3-5 seconds for the current fault code to appear (AF).
- To review the previous faults use the arrow buttons (F1= Most Recent, F5= Oldest).
- To erase the faults that are in memory press both "L" keys at the same time.
- See the fault code chart on following pages for code number descriptions.

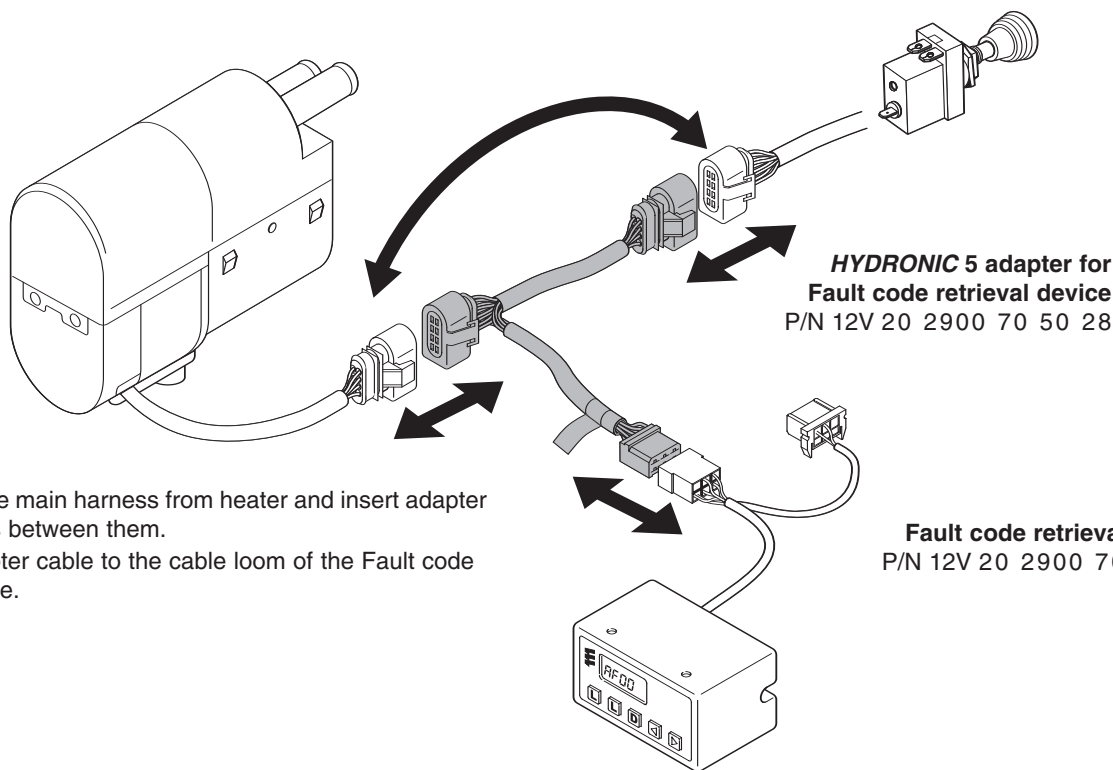

Hook Up

- Disconnect the main harness from heater and insert adapter cable harness between them.
- Connect adapter cable to the cable loom of the Fault code retrieval device.

Test Values

Resistance

Metering pump approx. 10 Ω for 12 volt heater; approximately 36 Ω for 24 volt heater
Glow Pin approx. 0.9 Ω

Checking the sensors

To check the sensors, measure the resistance at current temperature, see following diagrams:

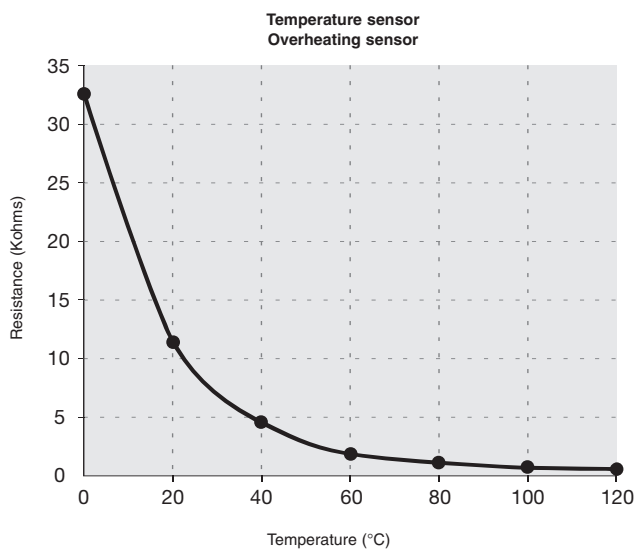

R > 2 Ω = open circuit
R < 50 Ω = short circuit

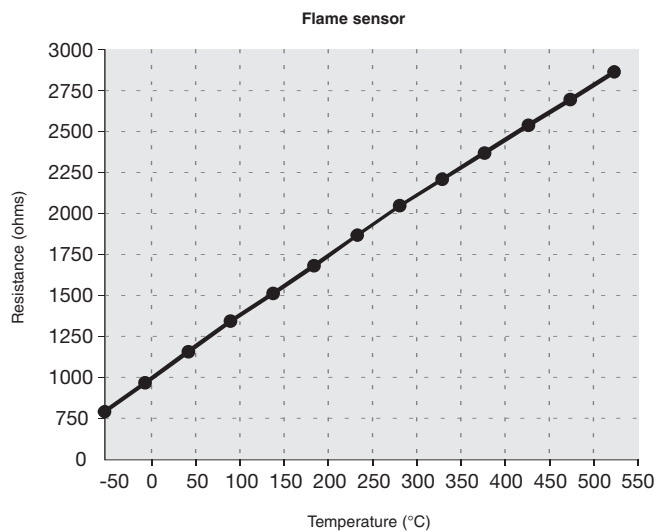

R > 3400 Ω = open circuit
R < 50 Ω = short circuit

Maintenance / Troubleshooting / Repair

Fault Code	Fault Description	Causes / Repair
000	Normal Operation	
010	Overvoltage	Check voltage between terminals 1(red) and 2(brown) at connector (B1). If voltage is > 15 volts then check battery, electrical leads and vehicle charging system.
011	Under voltage shut down	Check voltage between terminals 1(red) and 2(brown) at connector (B1). If voltage is < 10 volts then check battery, electrical leads and vehicle charging system.
012	Overheating	Check for possible causes of overheat (water circuit), Sensor. Check overheat switch resistance values. Temperature at temperature sensor or overheat sensor is greater than 125°C.
014	Possible overheating detected (difference evaluation)	Difference of measured values at temperature sensor >25°C (min. 80°C water temperature and metering pump in operation); Check temperature sensor and overheating sensor, replace if necessary. Check values from previous page.
015 fault coun-	Too many overheats	Remove cause of over heat. Reset control unit using 7 day timer or code retrieval device to unlock control unit. Permanent overheating timer reading exceeded. Heating enable only possible by means of diagnostics system (press both "LL" keys simultaneously).
017	Overheating detected	Temperature at temperature or overheating sensor > 130 °C, emergency OFF if Fault Code 012 or 014 not applicable; check water circuit, check temperature sensor and overheating sensor; replace if necessary. See graph on previous page.
020	Open circuit - glow pin	Check glow pin and electrical leads for continuity, replace if necessary.
021	Short circuit - glow pin	Check glow pin and electrical leads for continuity, replace if necessary.
030	Combustion air blower motor	Blower impeller or electric motor may be jammed (frozen solid, dirty, etc.) Fix jam, replace electric motor if necessary.
031	Combustion air blower motor	Check lead to combustion air motor for continuity, replace motor if necessary.
032 sary.	Combustion air blower motor short-circuit	Check combustion air blower motor (electric motor); replace if necessary. Check power supply (chafed, corroded etc.)
038	Vehicle fan relay control break	Check electric lead to relay, fix break, replace relay if necessary For wiring harness (20 2900 70 04 01) without relay, replace harness.
039	Vehicle fan relay control short circuit	Check electric lead to relay, fix break, replace relay if necessary For wiring harness (20 2900 70 04 01) without relay, replace harness.
041	Water pump break	Check supply lead to water pump for continuity, remedy break, replace water pump if necessary.
042 re-	Water pump short-circuit	Check supply lead to water pump for short circuit, check water pump, place water pump if necessary.
047	Short circuit - fuel metering pump	Check for wires for short to fuel metering pump. Test fuel metering pump. Replace if necessary.



Maintenance / Troubleshooting / Repair

Fault Code	Fault Description	Causes / Repair
048 replace	Open circuit - fuel metering pump	Check supply lead to metering pump for continuity, remedy break, if necessary.
050	Too many no start attempts	Safety time counter reading exceeded. Reset control unit using 7 day Timer or fault code retrieval device to unlock control unit.
051	Faulty flame recognition	At start, if flame sensor is a above 70°C > 240 seconds; check exhaust gas and combustion air supply, check flame sensor, replace if necessary. For flame sensor values see graph on previous page.
052	No start safety time exceeded	No flame detected on start attempt. Check fuel delivery and fuel supply, Check exhaust gas and combustion air ducts.
053	Flame cutout in boost mode	Heater has started successfully the flame has extinguished. Check fuel supply. Check combustion air and exhaust flow. Check flame sensor resistance value. Replace flame sensor if necessary.
054	Flame cutout in high mode	Heater has started successfully the flame has extinguished. Check fuel supply. Check combustion air and exhaust flow.
056	Flame cutout in low mode	Check flame sensor resistance value.
060	Open circuit - temperature sensor	Temperature sensor detects a value beyond it's range. Check connections. Check sensor resistance values between 11 and 12 at connector B2 > 2 M (if open circuit).
061	Short circuit - external temperature sensor	Check connections. Check sensor resistance values between 11 and 12 at connector B2 < 50 Ω (if short circuit). Temperature sensor values on previous pages.
064	Open circuit - flame sensor	Sensor is sensing value outside of range. Check connection leads. Resistance values between 1 and 2 at connector B2 > 3040 Ω (if open circuit).
065	Short circuit - flame sensor	Check connection leads. Resistance values between 1 and 2 at connector B2 > 780 Ω (if short circuit). Flame sensor values on page 17.
071	Open circuit - overheat sensor	Check connection leads. Resistance values between 9 and 10 at connector B2 > 2 M Ω (if open circuit).
072	Short circuit - overheat sensor	Check connection leads. Resistance values between 9 and 10 at connector B2 < 50 M Ω (if short circuit).
091	External interference voltage	Error in controller from interference voltage from vehicle network possible causes: poor batteries, poor battery charges, other interference sources; eliminate interference voltages.
090 092 -103	Controller defect	Control unit malfunction due to interference voltage from vehicle electrical system; possible causes low batteries, charges, other sources of interference, eliminate interference voltages. Internal faults detected in microprocessor/memory. Replace control unit. Internal failure. Replace control unit.
Faults not shown by the diagnosis system <i>HYDRONIC</i> won't start		After switching <i>HYDRONIC</i> on, the water pump and vehicle fan start immediately. <ul style="list-style-type: none">· Remove and check temperature sensor. After switching <i>HYDRONIC</i> on, the vehicle fan starts, functioning "pre-venting" is activated.· Changeover venting to heating at "heating/venting changeover switch.

Fuel Quantity Test

The fuel Quantity should be tested if the heater has difficulty starting or maintaining a flame, using graduated cylinder part # 5520004 10ml.

Note: Measure the fuel quantity when the battery is sufficiently charged. At least 11V and at most 13V should be applied at the control unit during measurement.

Preparation

- Remove metering pump cover in the cases of SC versions.
- Pull the fuel line off the combustion chamber and insert into a graduated measuring glass.
- Switch the heater on, when fuel delivery is uniform (approximately 45 seconds after switching on), the fuel line is full and bled.
- Switch heater off.
- Empty measuring glass and replace.

Measurement

- Switch heater on.
- Fuel delivery starts automatically approximately 40 seconds after switching on.
- Hold the graduated measuring glass at the glow pin height during measurement.
- After 90 seconds of fuel delivery, it will shut off automatically.
- Switch heater off.
- Read off quantity of fuel delivery in the graduated measuring glass.

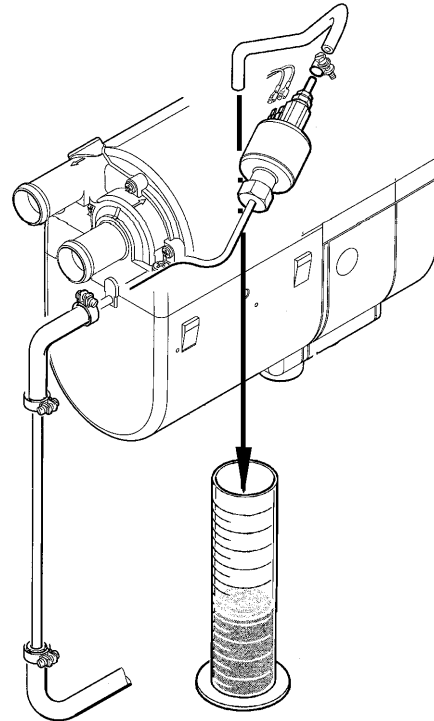

Evaluation

← Diesel			Gasoline →		
Hydronic D4W SC	Hydronic D5W SC	Hydronic D5W S	Hydronic B4W SC	Hydronic B5W SC Hydronic B5W S	
8.4 cm ³ / 90 seconds	9.5 cm ³ / 90 seconds	9.5 cm ³ / 90 seconds	11.3 cm ³ / 90 seconds	11.9 cm ³ / 90 seconds	Max
7.3 cm ³ / 90 seconds	8.5 cm ³ / 90 seconds	8.5 cm ³ / 90 seconds	10.1 cm ³ / 90 seconds	10.7 cm ³ / 90 seconds	Min

If measured quantity of fuel is over or under the nominal value, the metering pump must be replaced or fuel restriction eliminated.

Maintenance / Troubleshooting / Repair

Repair Steps covered are for the Hydronic 4 & 5 SC versions - other models are similar

Disassembly / Assembly

- | | | | |
|---|---------------------------|----|------------------------------------|
| 1 | Cover, metering pump | 7 | Flame sensor |
| 2 | Water pump, assembly | 8 | Cable harness |
| 3 | Metering pump and bracket | 9 | Electric motor, complete |
| 4 | Cover, blower | 10 | Combustion chamber with flame tube |
| 5 | Control unit and cover | 11 | Heat exchanger and jacket |
| 6 | Glow pin | | |

1 Cover, metering pump

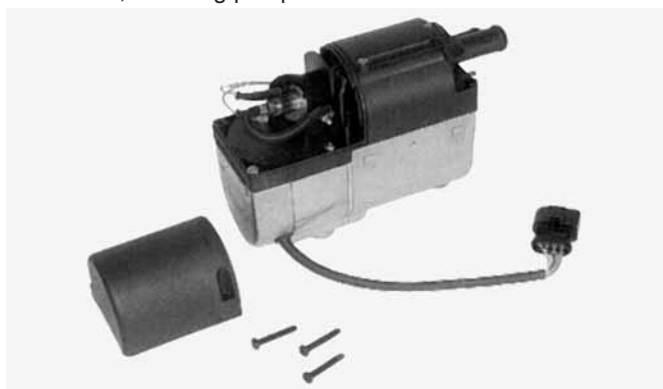

4 Cover, blower

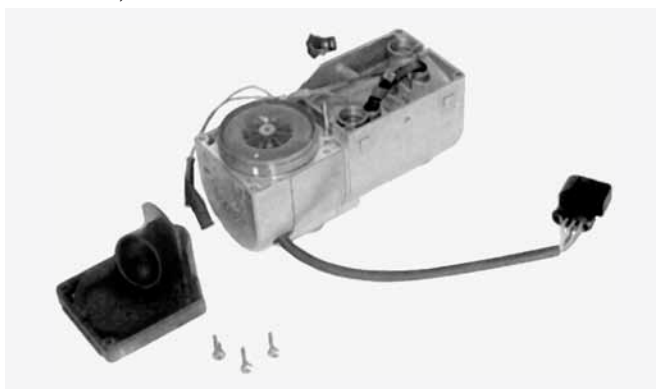

2 Water pump assembly. When mounting, place O-rings on connection on water pump housing

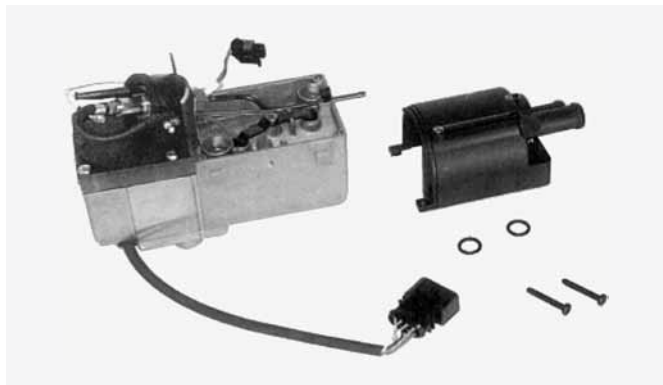

5 Control unit and cover

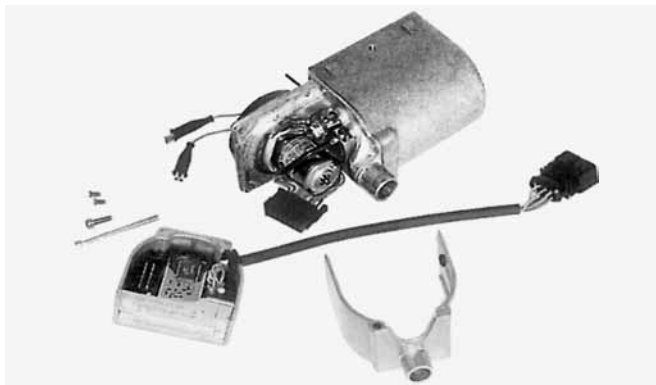

3 Metering pump and bracket

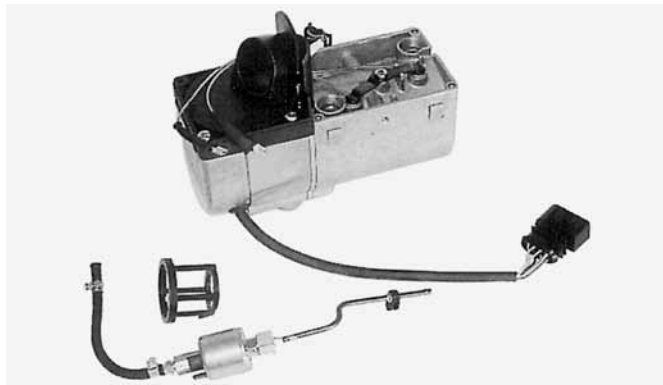

6 Glow pin



- 7 Flame sensor, For removal of tab receptacles, use AMP extractor tool

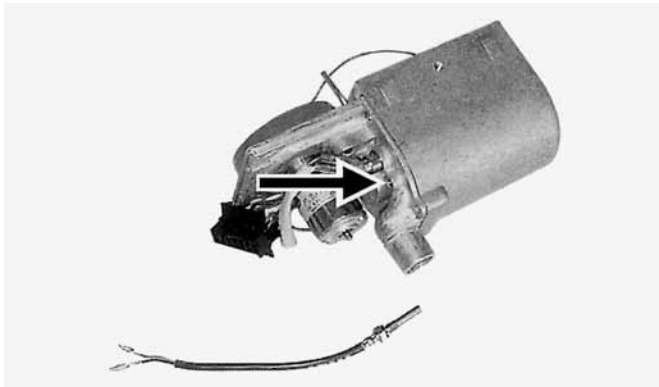

- 10 Combustion chamber with flame tube



- 8 Cable Harness

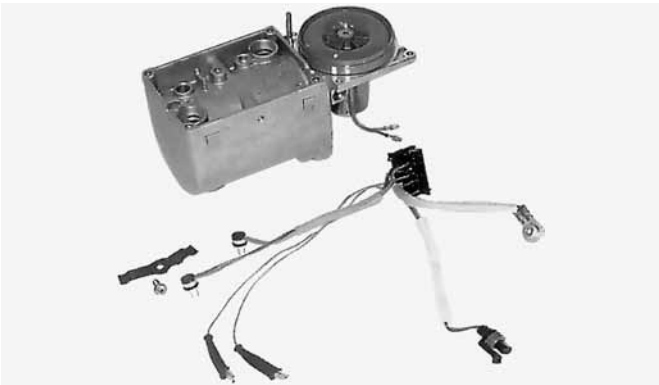

- 11 Heat exchanger and jacket, Align slot on heat exchanger (arrow) with lug in jacket

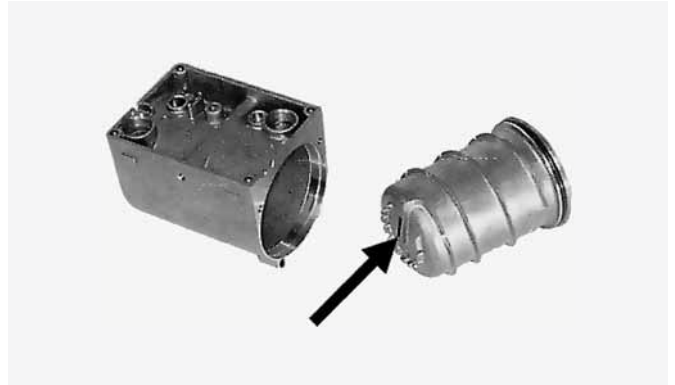

- 9 Electric motor, complete

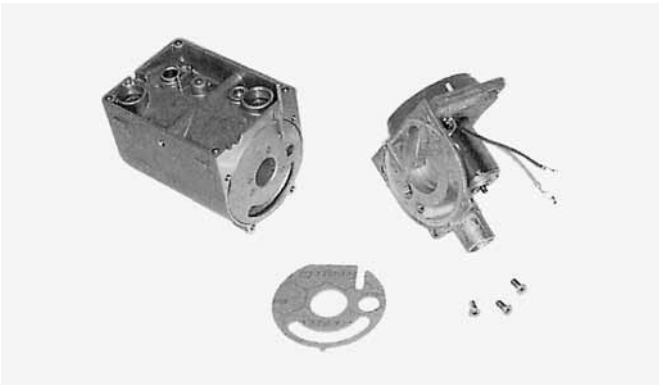

Magnetic Drive Coolant Pump Cleaning

It is advised to make this procedure part of an annual pre-season check up for this heater.

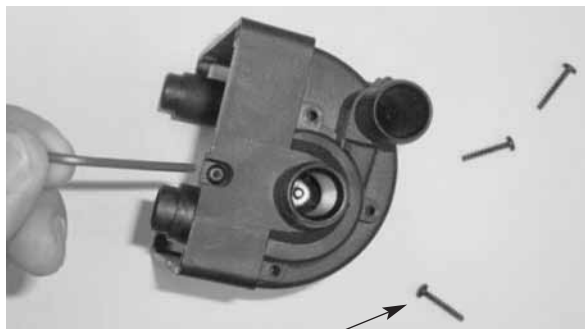

Remove the four screws holding the coolant pumps two halves together.

“O” Ring 45mm x 1 1/2 m, Part #: 556 00 06

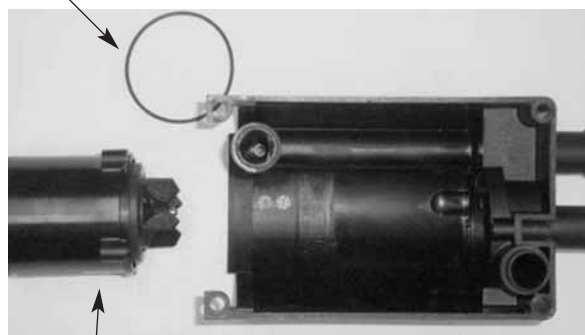

Motor / Impeller Assembly

Pump Motor

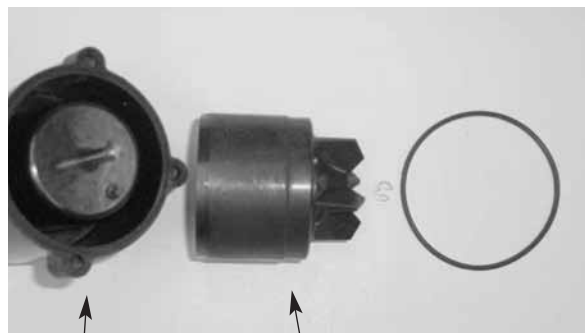

Motor Assembly

Impeller with Magnet

Parts Diagram - Hydronic 4 / 5 W SC - Face Lift - 12 volt - Diesel & Gasoline versions

Model 20 1824 05
Model 25 2257 05
Model 20 1820 05
Model 25 2219 05

Model 25 2325 05
with external FMP

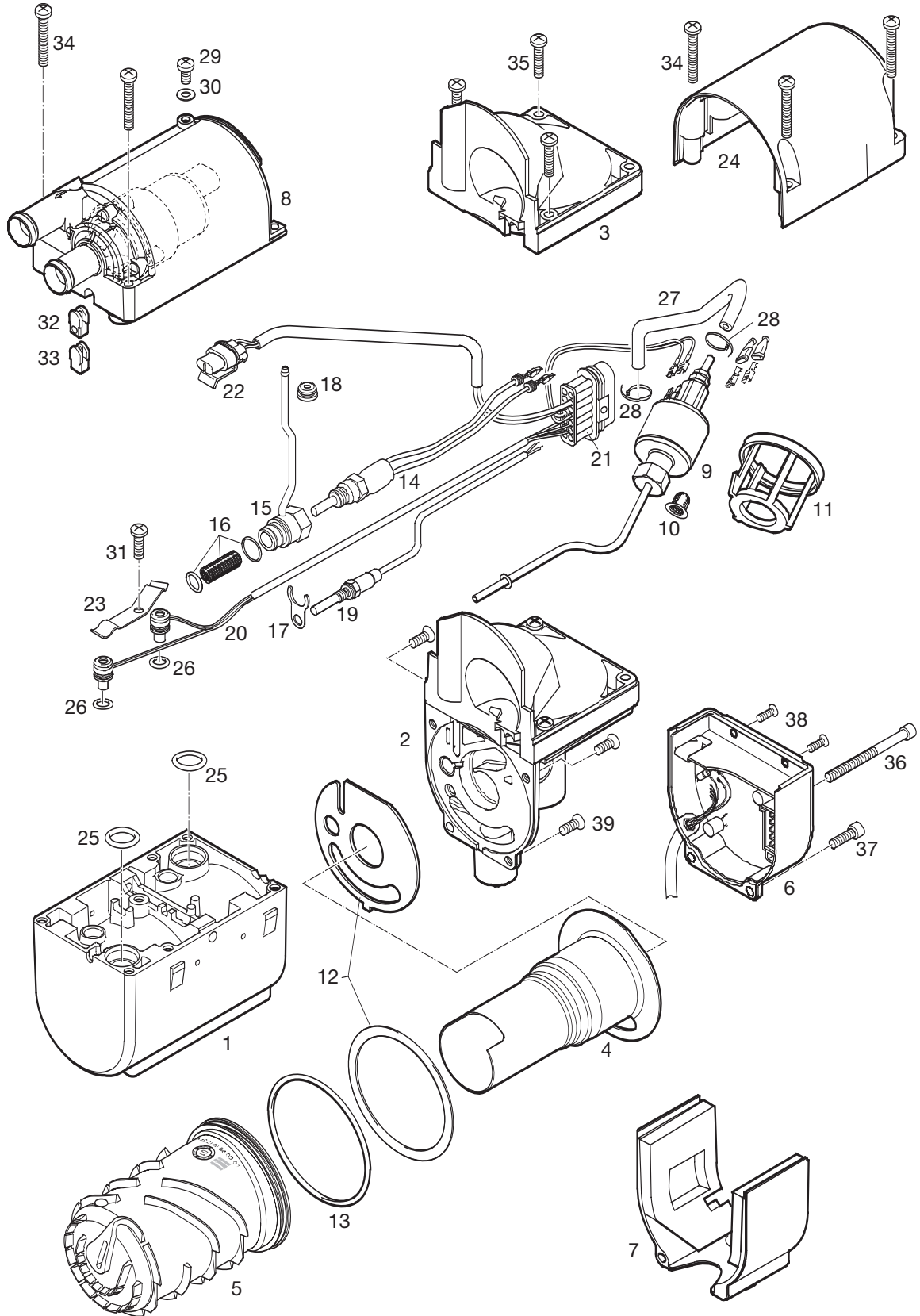



Heater Components

Face Lift "SC" Heaters

HYDRONIC 4 / 5 W SC - Face Lift - 12 volt - Diesel & Gasoline versions

Description & Part #'s

Ref. No.	Description	Part Number	Model #	20 1824 05 12v	25 2257 05 12v	20 1820 05 12v	25 2219 05 12v	25 2325 05 12v
1	Outer casing	25 2149 01 01 01		•	•	•	•	•
2	Combustion air blower with cover	20 1819 99 16 00		•	•	•	•	•
3	Cover	25 1917 01 00 02		•	•	•	•	•
4	Burner	20 1818 10 00 00 25 2216 10 00 00		•	•	•	•	•
5	Heat exchanger	25 2149 06 00 01		•	•	•	•	•
6	Control unit	22 5201 03 00 02 22 5201 04 00 06 22 5201 00 20 04 22 5201 01 90 02		•	•	•	•	•
7	Cover	20 1752 99 01 03		•	•	•	•	•
8	Coolant Pump	25 2219 25 00 00		•	•	•	•	•
9	Fuel metering pump	22 4504 03 00 00		•	•	•	•	•
	Internal fuel pipe	25 2118 01 00 01						•
	Intermediate piece	25 2137 01 00 01						•
10	Integrated fuel filter	20 1312 00 00 06		•	•	•	•	•
11	Holder fuel metering pump	25 1917 01 00 07		•	•	•	•	•
12	Seal	20 1820 99 00 01		•	•	•	•	•
13	O-Ring 74 x 3 mm	320 75 104		•	•	•	•	•
14	Glow pin with cable section	25 2106 01 10 00		•	•	•	•	•
15	Plug connection	20 1752 01 10 00 25 2147 01 14 00		•	•	•	•	•
16	Atomizing Screen with O rings	20 1752 99 01 02 25 2121 99 01 13		•	•	•	•	•
17	Holder	20 1752 01 00 04		•	•	•	•	•
18	Groomet	20 1752 01 00 02		•	•	•	•	•
19	Flame sensor	25 1920 35 00 00		•	•	•	•	•
20	Overheat sensor with cable section	25 2147 01 20 00 25 2219 01 20 00		•	•	•	•	•
21	Plug kit 14 pin	22 1000 30 10 10		•	•	•	•	•
22	Cable section Waterpump	20 1753 01 18 00		•	•	•	•	•
23	Spring leaf	25 1922 01 00 05		•	•	•	•	•
24	Cover fuel metering pump	20 1752 01 00 03 25 1917 01 00 03		•	•	•	•	•
25	O-Ring 14 x 2.6	22 1000 70 00 06		•	•	•	•	•
26	O-Ring 7 x 2	22 1000 70 00 09		•	•	•	•	•
27	Hose	25 1917 01 00 11		•	•	•	•	•
28	Cable band	209 31 071		•	•	•	•	•
29	Screw	25 1917 25 00 12		•	•	•	•	•

Heater Components

Face Lift "SC" Heaters

HYDRONIC 4 / 5 W SC - Face Lift - 12 volt - Diesel & Gasoline versions

Description & Part #'s

Ref. No.	Description	Part Number	Model #	20 1824 05 12v	25 2257 05 12v	20 1820 05 12v	25 2219 05 12v	25 2325 05 12v
30	O-Ring 5 x 1.5 mm	Hardware		•	•	•	•	•
31	Tapite screw M5 x 12	109 10 153		•	•	•	•	•
32	Sleeve	25 1917 01 00 05			•		•	•
33	Sleeve	20 1752 01 00 06			•		•	•
34	Tapite screw M5 x 35 Torx	109 10 154		•	•	•	•	•
35	Tapite screw M5 x 25 Torx	109 10 152		•	•	•	•	•
36	Cheese-head screw M5 x 65 Torx	100 10 350		•	•	•	•	•
37	Tapite screw M5 x 16 Torx	109 10 151		•	•	•	•	•
38	Tapite screw M4 x 10 Torx	109 10 150		•	•	•	•	•
39	Counter sunk screw M5 x 12 Torx	102 10 302		•	•	•	•	•

Notes:



Parts Diagram - Hydronic 4 / 5 W SC - Face Lift - 12 volt - Diesel & Gasoline versions

- Model 20 1824 05
- Model 20 1820 05
- Model 25 2219 05
- Model 25 2257 05
- Model 25 2325 05

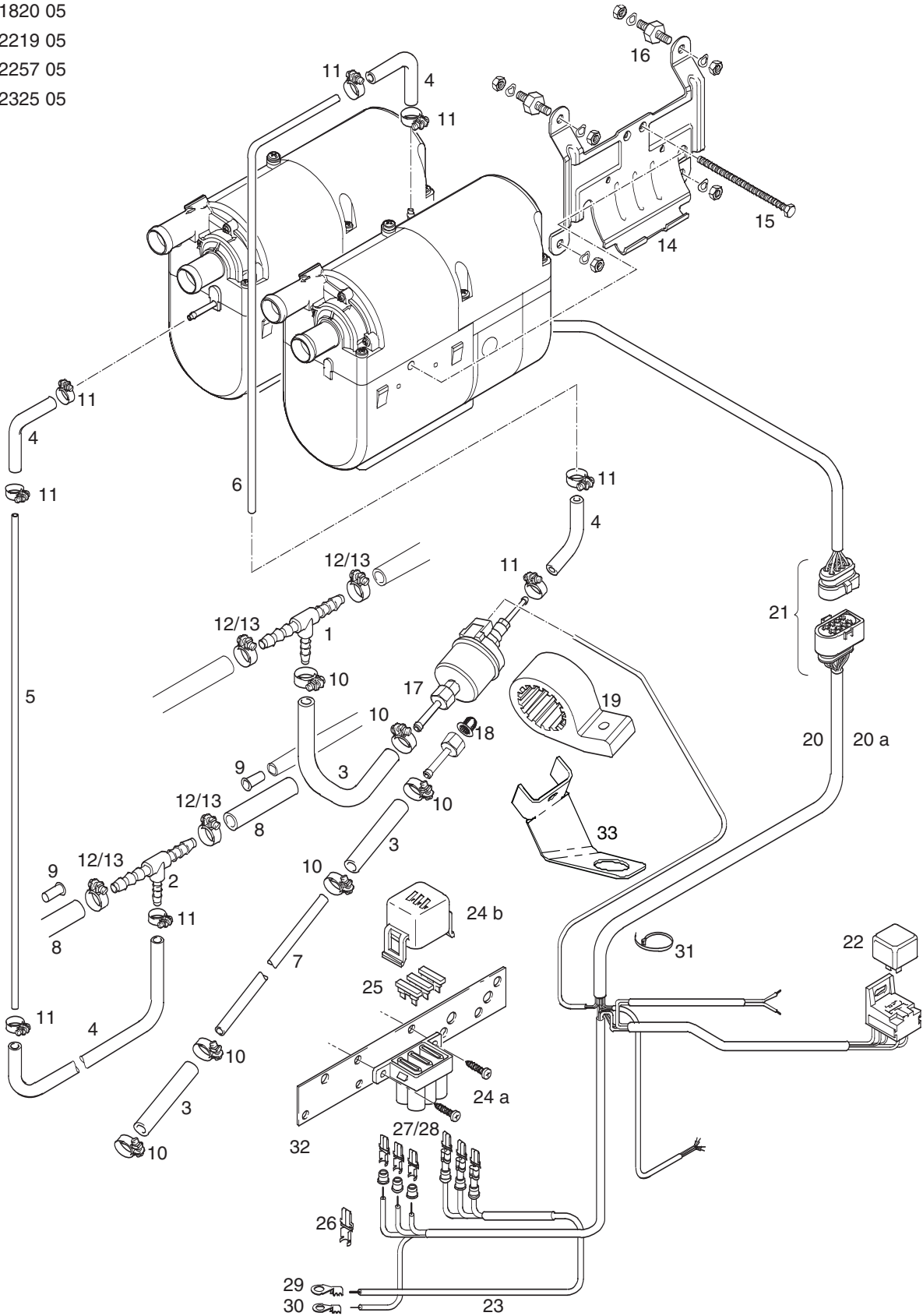



Hydronic 4 / 5 W SC - Face Lift - 12 volt - Diesel & Gasoline versions

Description & Part #'s

Ref. No.	Description	Part Number	Model #	20 1824 05 12v	25 2257 05 12v	20 1820 05 12v	25 2219 05 12v	25 2325 05 12v
01	T-piece 8 x 6 x8 mm	262 31 151		•	•	•	•	•
02	T-piece 8 x 4 x8 mm	262 31 155		•	•	•	•	•
03	Hose	360 75 350 -----		•	•	•	•	•
04	Hose 3.5mm x 3mm	360 75 300 -----		•	•	•	•	•
05	Plastic fuel line 2mm	890 31 117		•	•	•	•	•
06	Plastic fuel line 1.5mm	890 31 118		•	•	•	•	•
07	Plastic fuel line 2mm - Black	890 31 125		•	•	•	•	•
08	Hose 7.5mm	----- -----		•	•	•	•	•
09	Supporting sleeve with collar	-----		•	•	•	•	•
10	Hose clip 11mm	10 2068 01 10 98		•	•	•	•	•
11	Hose clip 9mm	10 2068 00 90 98		•	•	•	•	•
12	Hose clip 14mm	10 2068 01 40 98		•	•	•	•	•
13	Hose clip 12mm	10 2068 01 20 98		•	•	•	•	•
14	Holder	25 2220 80 00 01		•	•	•	•	•
15	Central screw	100 10 258		•	•	•	•	•
16	Metal rubber buffer 6 mm	20 1185 00 00 01		•	•	•	•	•
17	Fuel metering pump	22 4517 04 00 00		•	•	•	•	•
18	Fuel filter	20 1312 00 00 06		•	•	•	•	•
19	Holder metering pump	22 1000 50 03 00		•	•	•	•	•
20	Main harness - J.E - Universal w/relay	25 1917 80 10 00 25 1917 80 11 00		•	•	•	•	•
20a	Main harness ESPAR	20 2900 70 05 02 20 2900 70 05 03		•	•	•	•	•
21	Connection Kit	22 1000 30 10 21		•	•	•	•	•
22	Relay	203 00 065		•	•	•	•	•
23	Cable	22 1000 31 28 00		•	•	•	•	•
24a	Fuse holder, receptable housing	22 1000 31 06 01		•	•	•	•	•
24b	Fuse holder, cover	22 1000 31 06 02		•	•	•	•	•
25	Fuse	25 A 204 00 089 20 A 5670055 5 A 204 00 079		•	•	•	•	•
26	Terminal	206 52 136		•	•	•	•	•
27	Terminal	206 52 133		•	•	•	•	•
28	Terminal	206 52 134		•	•	•	•	•
29	Eyelet	Hardware		•	•	•	•	•
30	Eyelet	Hardware		•	•	•	•	•
31	Cable band	25 1801 80 02 00		•	•	•	•	•
32	Combination bracket, fuses and fan relay	22 1000 51 21 00		•	•	•	•	•
33	Angle bracket	20 2900 40 01 04		•	•	•	•	•

Parts Diagram - Hydronic 4 / 5 W SC - Face Lift - 12 volt - Diesel & Gasoline versions

Model 20 1824 05
Model 25 2257 05
Model 20 1820 05
Model 25 2219 05
Model 25 2325 05

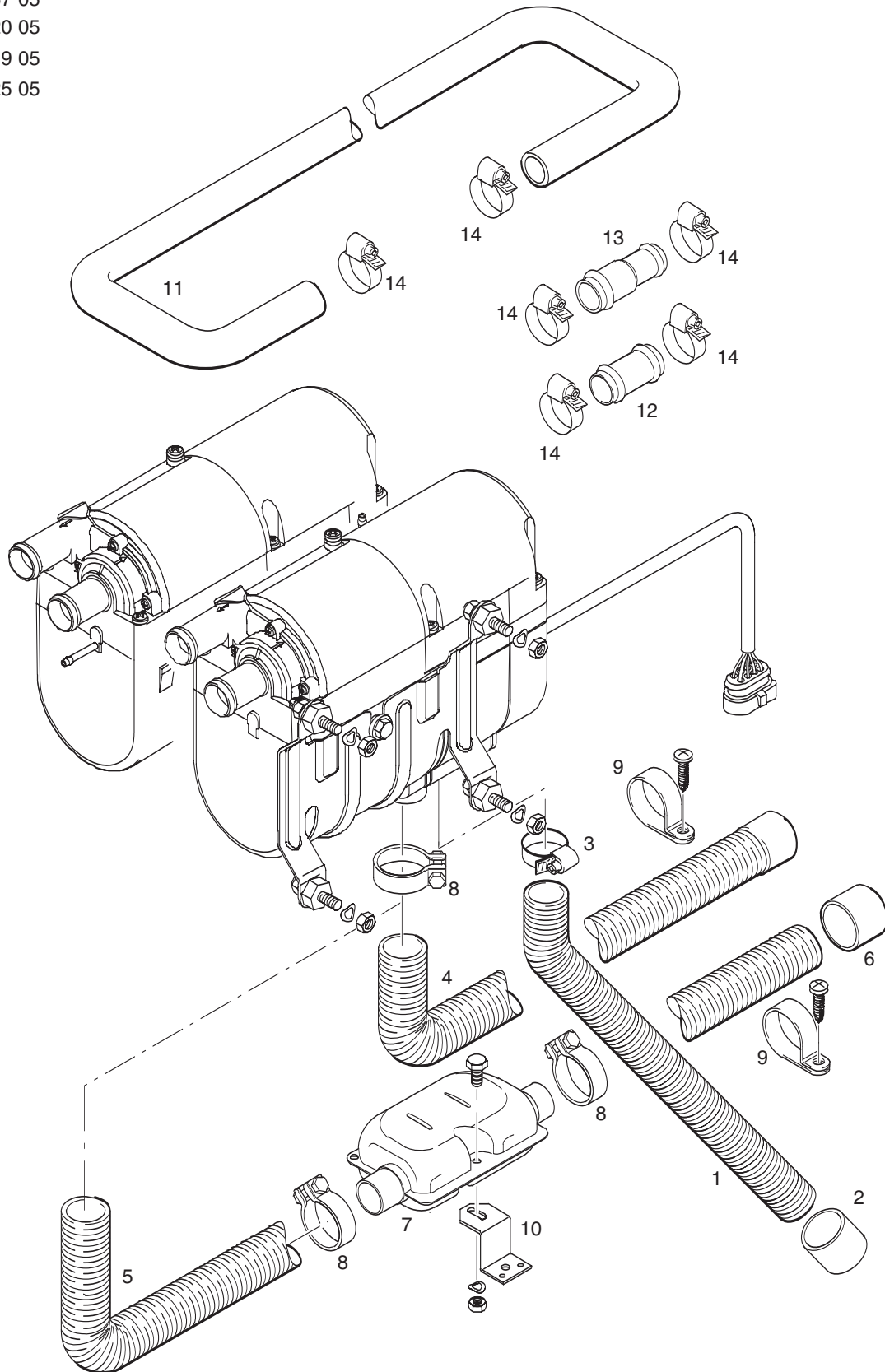



Heater Components

Face Lift "SC" Heaters

Hydronic 4 / 5 W SC - Face Lift - 12 volt - Diesel & Gasoline versions

Description & Part #'s

Ref. No.	Description	Part Number	Model #	20 1824 05 12v	25 2257 05 12v	20 1820 05 12v	25 2219 05 12v	25 2325 05 12v
1	Flexible air intake hose - 20mm x 1mtr	360 00 099		•	•	•	•	•
	Double-pipe LW 19, sound damping	-----		•	•	•	•	•
2	End cap with bar	25 1688 80 12 01		•	•	•	•	•
3	Hose clamp 16 - 32mm	10 2067 01 60 25		•	•	•	•	•
4	Exhaust hose - 24mm x 1mtr / with cap	25 1774 80 02 00		•	•	•	•	•
5	Exhaust hose 24 mm	360 61 299		•	•	•	•	•
6	Exhaust end cap w/bar	25 1729 80 06 00		•	•	•	•	•
7	Exhaust silencer	25 1864 81 01 00 22 1000 40 09 00		•	•	•	•	•
8	Exhaust clamp	22 1000 50 05 00		•	•	•	•	•
9	"P" clamp 28mm	152 09 010		•	•	•	•	•
10	Double angle bracket	20 1533 88 00 07		•	•	•	•	•
11	Water Hose - Moulded - 18mm	20 1690 81 00 01		•	•	•	•	•
12	Water hose union - 18mm	20 1528 88 00 03		•	•	•	•	•
13	Water hose union - 18mm - 15mm	20 1645 80 02 01		•	•	•	•	•
14	Hose clamp 20 - 32mm	10 2065 02 00 32		•	•	•	•	•

Parts Diagram - Hydronic B5 / D5 - 12 & 24 volt - Diesel & Gasoline versions

Model 20 1819 05
Model 25 2217 05
Model 25 2218 05

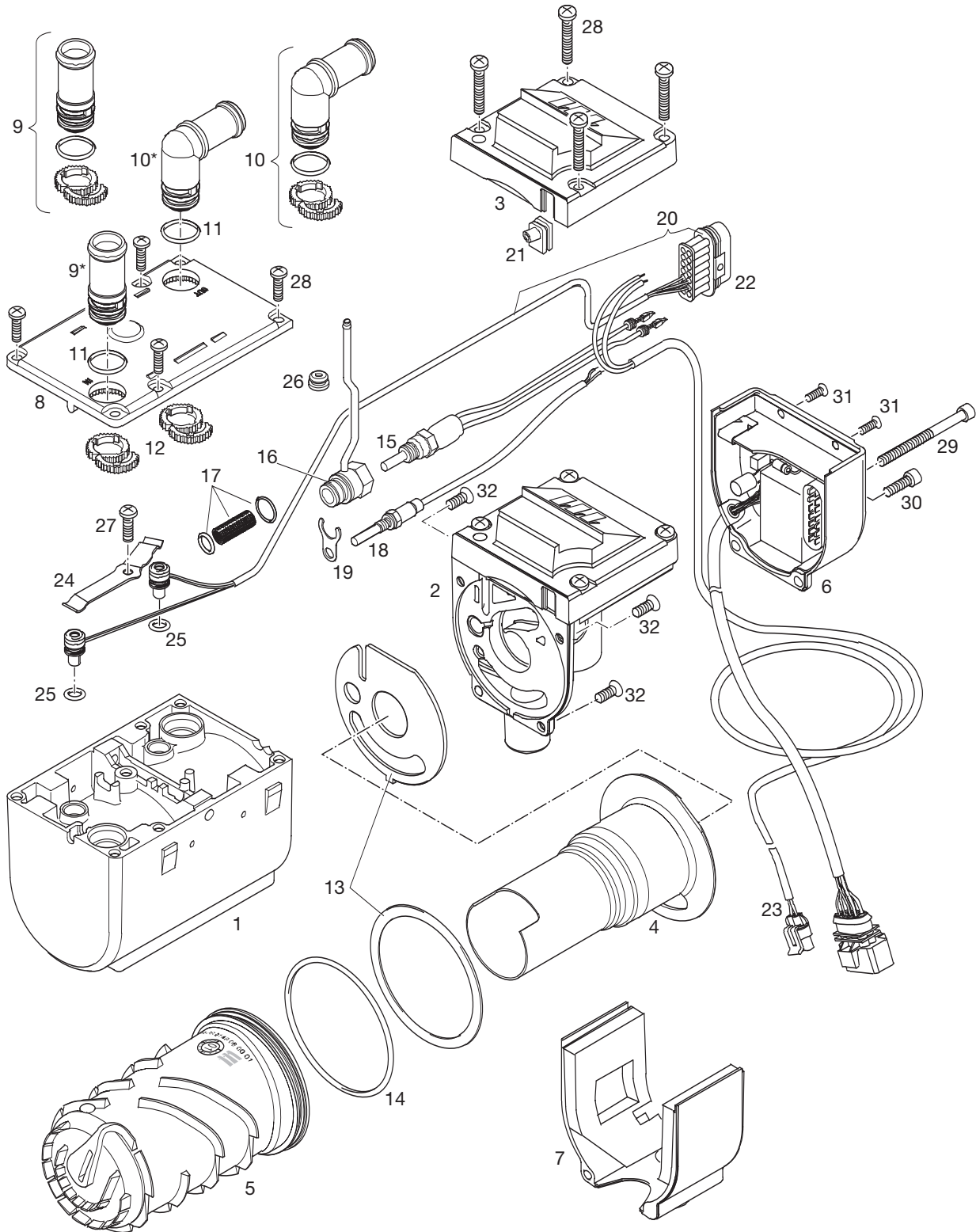



Heater Components

Face Lift "S" Heaters

Hydronic B5 / D5 - 12 & 24 volt - Diesel & Gasoline versions

Description & Part #'s

Ref. No.	Description	Part Number	Model #	20 1819 05 12V	25 2217 05 12V	25 2218 05 24V
1	Casing	25 2149 01 01 01		•	•	•
2	Combustion air blower with cover	20 1819 99 16 00 25 2146 99 17 00		•	•	•
3	Cover	25 2217 01 00 01		•	•	•
4	Burner	20 1818 10 00 00 25 2216 10 00 00 25 2146 10 00 00		•	•	•
5	Heat exchanger	25 2149 06 00 01		•	•	•
6	Control unit	22 5201 00 20 04 22 5201 01 90 02 22 5202 01 10 01		•	•	•
7	Cover - heater base	20 1756 99 01 03		•	•	•
8	Cover	25 2216 01 00 02		•	•	•
9	Hose barb assly 18mm	25 2216 99 01 06		•	•	•
10	Hose barb assly - 90° - mm	25 2216 99 01 05		•	•	•
11	O-Ring 16x2	22 1000 70 00 05		•	•	•
12	Hose barb locks	25 2216 01 00 10		•	•	•
13	Gasket / seal set	20 1820 99 00 01		•	•	•
14	O-Ring - 74x3	22 1000 70 00 02		•	•	•
15	Glow pin	25 2106 01 10 00 25 2107 01 10 00		•	•	•
16	Glow plug connection	20 1756 01 10 00 25 2121 01 14 00		•	•	•
17	Glow pin lining and 2 O-rings	20 1752 99 01 02 25 2121 99 01 13		•	•	•
18	Flame sensor	25 1920 35 00 00		•	•	•
19	Holder	20 1752 01 00 04		•	•	•
20	Over heat sensor with cable	25 2150 01 20 00		•	•	•
21	Grommet for cable	25 2216 01 17 01		•	•	•
22	Control unit plug kit	22 1000 30 10 10		•	•	•
23	Water pump harness	25 2009 01 15 00		•	•	•
24	Spring	25 1922 01 00 05		•	•	•
25	O-ring 7 x 2	22 1000 70 00 09		•	•	•
26	Grommet	20 1756 01 00 04		•	•	•
27	Taptite screw M5 x 12 torx	109 10 153		•	•	•
28	Taptite screw M5 x 25 torx	109 10 152		•	•	•
29	Cheese-head screw M5 x 65 torx	100 10 350		•	•	•
30	Taptite screw M5 x 16 torx	109 10 151		•	•	•
31	Taptite Screw M4 x 10 torx	109 10 150		•	•	•
32	Countersunk screw M5 x 12 torx	102 10 302		•	•	•

Parts Diagram - Hydronic B5 / D5 - 12 & 24 volt - Diesel & Gasoline versions

Model 20 1819 05
Model 25 2217 05
Model 25 2218 05

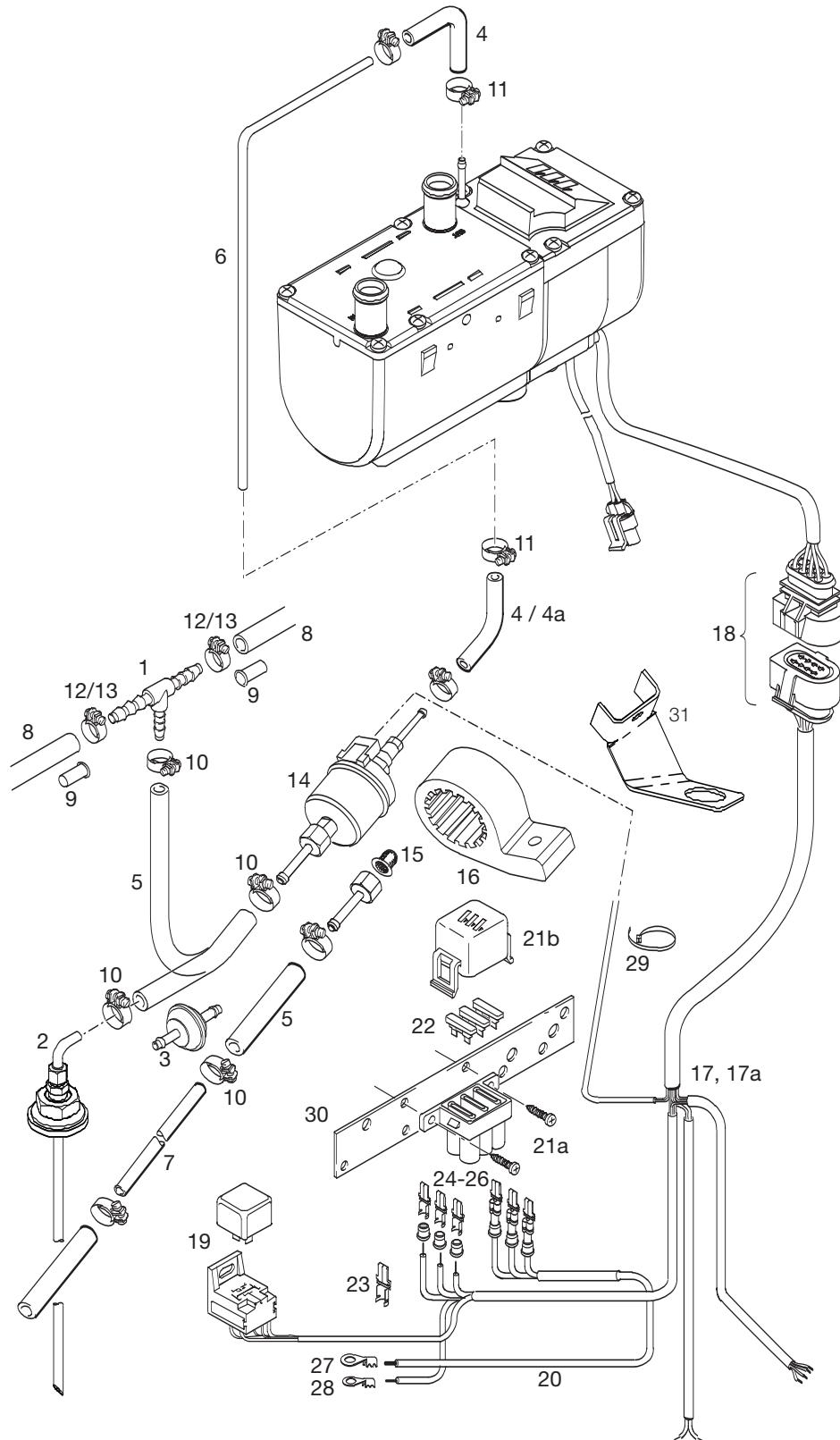



Hydronic B5 / D5 - 12 & 24 volt - Diesel & Gasoline versions

Description & Part #'s

Ref. No.	Description	Part Number	Model #	20 1819 05 12v	25 2217 05 12v	25 2218 05 24v
1	T-piece 8 x 6 x 8mm	262 31 151		•	•	•
2	Fuel pick up pipe 2.0mm - Universal	20 2900 20 20 10				•
3	Fuel filter	25 1226 89 00 37				•
4	Fuel hose 3.5 x 3mm	360 75 300	•			
4a	Hose	-----				
5	Hose 5 x 3mm	360 75 350	•	•		•

6	Plastic fuel line 1.5 mm	890 31 118	•	•	•	•
	Optional 2.0 mm	890 31 117	•	•	•	•
7	Plastic fuel line 2 mm	890 31 125	•	•	•	•
8	Hose 7.5mm	-----	•	•	•	•
9	Supporting sleeve with collar	-----	•	•	•	•
10	Clamp 11mm	10 2068 01 10 98	•	•	•	•
11	Hose clamp 9mm	10 2068 00 90 98	•	•	•	•
12	Hose clamp 14mm	10 2068 01 40 98	•	•	•	•
13	Hose clamp 12mm	10 2068 01 20 98	•	•	•	•
14	Fuel metering pump	12 V 22 4517 04 00 00 24 V 25 1942 45 00 00	•	•		•
15	Fuel Basket Filter	20 1312 00 00 06	•	•	•	•
16	Holder metering pump	22 1000 50 03 00	•	•	•	•
17	Main harness - J.E Universal w/relay	12 V 25 1917 80 10 00 24 V 25 2009 80 10 00	•	•		•
17a	Main harness ESPAR	20 2900 70 05 02	•	•	•	•
18	Connector kit	22 1000 30 10 21	•	•	•	•
19	Relay	12 V 203 00 065 24 V 203 00 066	•	•		•
20	Cable	22 1000 31 28 00	•	•	•	•
21a	Fuse holder, receptacle housing	22 1000 31 06 01	•	•	•	•
21b	Fuse holder, cover	22 1000 31 06 02	•	•	•	•
22	Fuse	25 A 204 00 089 20 A 5670055 15 A 5670053 5 A 204 00 079	•	•	•	•
23	Terminal Fe	206 52 136	•	•	•	•
24	Terminal Fe	206 00 182				•
25	Terminal Fe	206 52 133	•	•	•	•
26	Terminal Fe	206 52 134	•	•	•	•
27	Eyelet	Hardware	•	•	•	•
28	Eyelet	Hardware	•	•		
29	Cable band	25 1801 80 02 00	•	•	•	•
30	Combination bracket, fuses and fan relay	22 1000 51 21 00	•	•	•	•

Parts Diagram - Hydronic B5 / D5 - 12 & 24 volt - Diesel & Gasoline versions

Model 20 1819 05
Model 25 2217 05
Model 25 2218 05

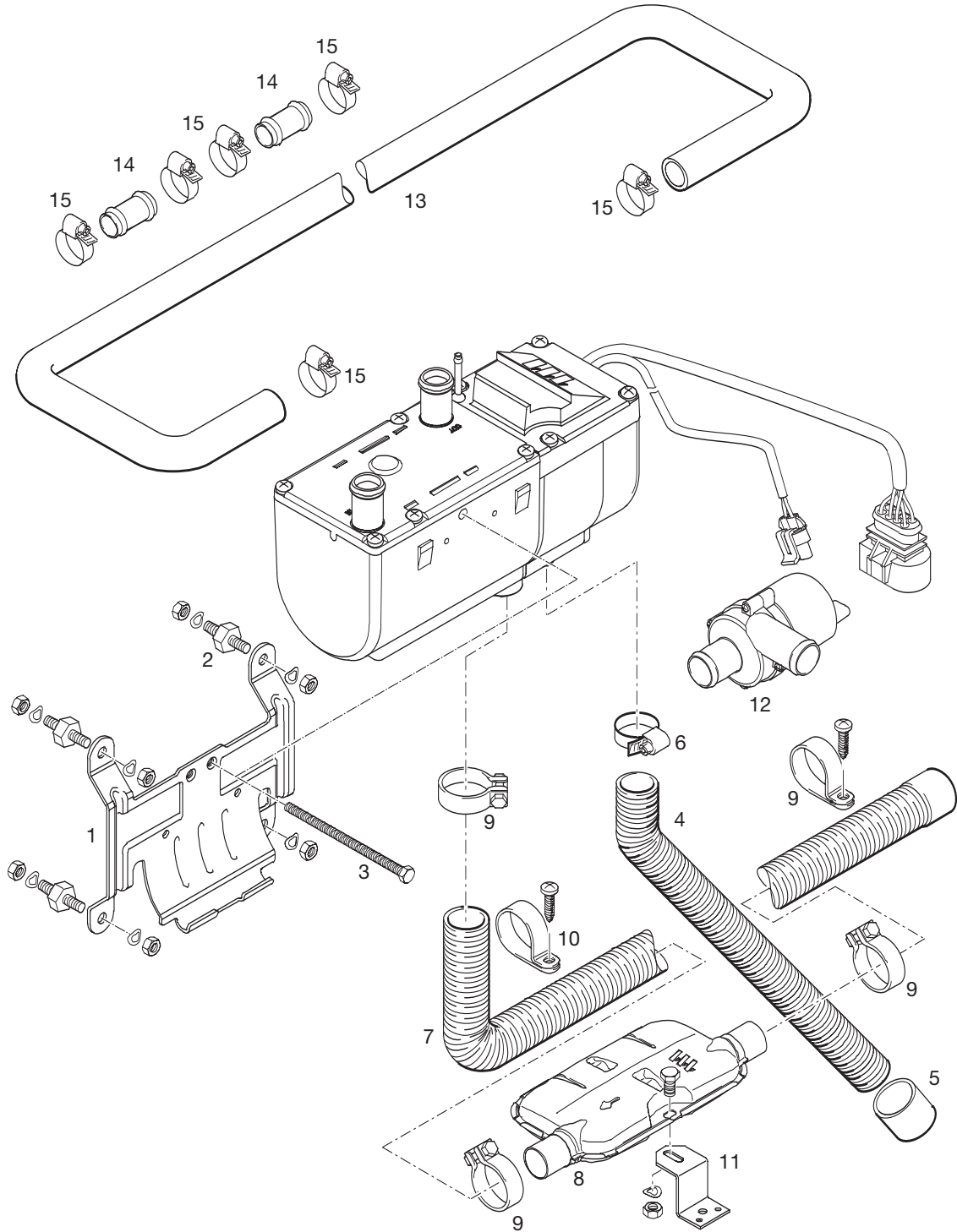



Heater Components

Face Lift "S" Heaters

Hydronic B5 / D5 - 12 & 24 volt - Diesel & Gasoline versions

Description & Part #'s

Ref. No.	Description	Part Number	Model #	20 1819 05 12v	25 2217 05 12v	25 2218 05 24v
1	Bracket	25 2220 80 00 01		•	•	•
2	Rubber mount 6mm	20 1185 00 00 01		•	•	•
3	Central screw, M6 x 97 Hex bolt	100 10 258		•	•	•
4	Flexible air intake hose	360 00 099		•	•	•
5	End cap with bar	25 1688 80 12 01		•	•	•
6	Hose clamp 16 - 25mm	10 2067 01 60 25		•	•	•
7	Exhaust Hose - 24mm x 1mtr with cap	25 1774 80 02 00		•	•	•
8	Exhaust silencer 24mm	22 1000 40 09 00		•	•	•
9	Exhaust clamp	22 1000 50 05 00		•	•	•
10	P clamp 28mm	152 09 010		•	•	•
11	Double angle bracket	20 1533 88 00 07		•	•	•
12	Coolant pump	12 V		•	•	•
		24 V		•	•	•
13	Coolant hose - moulded - 18mm	20 1690 81 00 01		•	•	•
14	Water hose union - 18mm	20 1528 88 00 03		•	•	•
15	Hose clip 20 - 32mm	10 2065 02 00 32		•	•	•

Parts Diagram - Hydronic D4 / D5 - 12 & 24 volt - Diesel & Gasoline versions

Model 25 2096 05
Model 25 1920 05
Model 25 2098 05
Model 25 2147 05 24 V
with external fuel pump

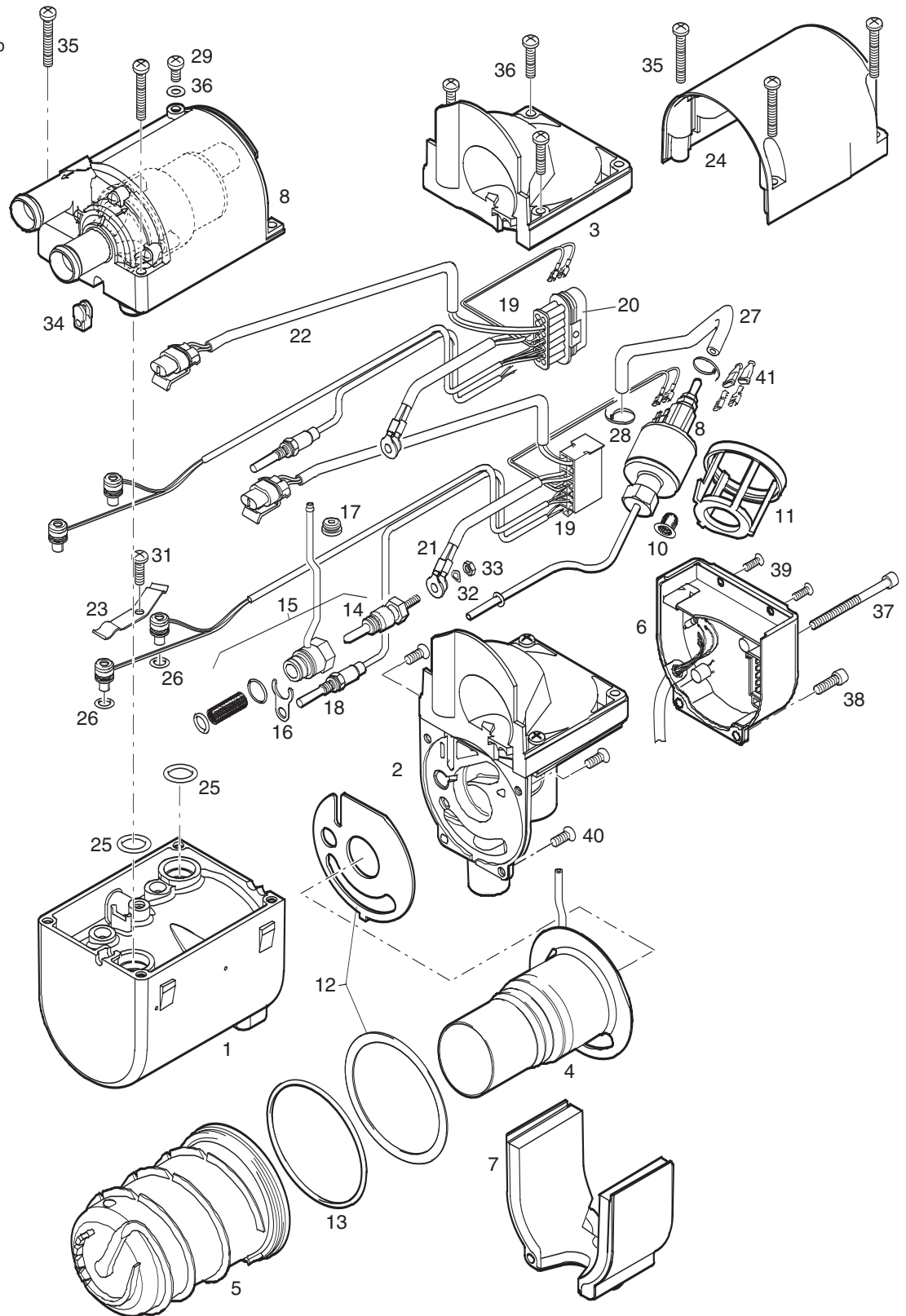

Heater Components

Early "SC" Heaters



Hydronic D4 / D5 - 12 & 24 volt - Diesel & Gasoline versions

Description & Part #'s

Ref. No.	Description	Part Number	Model #	25 2096 05 12V	25 1920 05 12V	25 2098 05 12V	25 2147 05 24V
1	Casing	25 1917 01 01 01		•			
		25 1920 01 01 01			•	•	
		25 1922 01 01 01					•
2	Combustion air blower with cover	25 1922 99 16 00			•	•	
		25 2013 99 16 00		•			
		25 2146 99 17 00				•	
3	Cover	25 1917 01 00 02		•	•	•	
		25 2137 01 00 02				•	
4	Burner	25 1917 19 00 00		•			
		25 1920 10 00 00			•	•	
		25 2146 10 00 00					•
5	Heat exchanger	25 1864 06 00 01		•			
		25 1922 06 00 01			•	•	•
6	Control unit	25 1917 55 00 01			•		
		22 5201 00 10 01		•			
		22 5201 00 30 01				•	
		22 5202 00 10 03					•
7	Cover	20 1752 99 01 03		•	•	•	
8	Pump	25 1920 25 00 00			•	•	
		25 2118 25 00 00			•	•	
9	Fuel metering pump	25 1917 45 00 00		•			
		25 1920 45 00 00			•	•	
10	Integrated fuel filter	20 1312 00 00 06		•	•	•	
11	Holder Fuel metering pump	25 1917 01 00 07		•	•	•	
12	Seal	20 1820 99 00 01		•	•	•	
13	O-Ring 74 x 33mm	320 75 104		•	•	•	
14	Glow pin	25 1864 01 10 00			•		
		25 2107 01 10 00				•	
		25 2106 01 10 00		•		•	
15	Plug connection complete	25 2147 01 13 00				•	
16	Holder	20 1752 01 00 04				•	
17	Sleeve	20 1752 01 00 02				•	
18	Flame sensor	25 1920 35 00 00		•	•	•	
19	Overheat sensor with cable	25 1920 01 17 00		•	•	•	
		25 2147 01 20 00				•	
20	Plug kit 14 pin	22 1000 30 10 10		•	•	•	
21	Cable section glow plug	25 1922 01 18 00		•	•	•	
		25 1920 01 18 00			•	•	
22	Cable section Waterpump	20 1752 01 18 00		•	•	•	
		20 1753 01 18 00			•	•	
23	Spring	25 1864 01 00 05		•			
		25 1922 01 00 05			•	•	
24	Cover Fuel metering pump	25 1917 01 00 03		•	•	•	

Heater Components

Early "SC" Heaters

Hydronic D4 / D5 - 12 & 24 volt - Diesel & Gasoline versions

Description & Part #'s

Ref. No.	Description	Part Number	Model #	25 2096 05 12V	25 1920 05 12V	25 2098 05 12V	25 2147 05 24V
25	O-Ring 14 x 2.6	22 1000 70 00 06		•	•	•	•
26	O-Ring 7 x 2	22 1000 70 00 09		•	•	•	•
27	Hose	25 1917 01 00 11		•	•	•	•
28	Cable band	209 31 071		•	•	•	•
29	Screw M4 x 10	25 1917 25 00 12		•	•	•	•
30	O-Ring 5x1.5 Din 37714	Hardware		•	•	•	•
31	Taptite screw M5 x 12 Torx	109 10 153		•	•	•	•
32	Spring washer 4mm	171 61 001		•	•	•	•
33	Hexagon nut 4mm Din 934-5	110 10 024		•	•	•	•
34	Sleeve	25 1917 01 00 05		•	•	•	•
35	Taptite screw M5 x 35 Torx	-----		•	•	•	•
36	Taptite screw M5 x 25	109 10 152		•	•	•	•
37	Cheese-head screw M5 x 65 Torx	100 10 350		•	•	•	•
38	Taptite screw M5 x 16 Torx	109 10 101		•	•	•	•
39	Taptite screw M4 x 10 Torx	109 10 150		•	•	•	•
40	Countersunk screw M5 x 12 Torx	102 10 302		•	•	•	•
41	Sleeve	320 31 120		•	•	•	•



Notes:

Parts Diagram - Hydronic D4 / D5 - 12 & 24 volt - Diesel & Gasoline versions

Model 25 2096 05
Model 25 1920 05
Model 25 2098 05
Model 25 2147 05
with external FMP

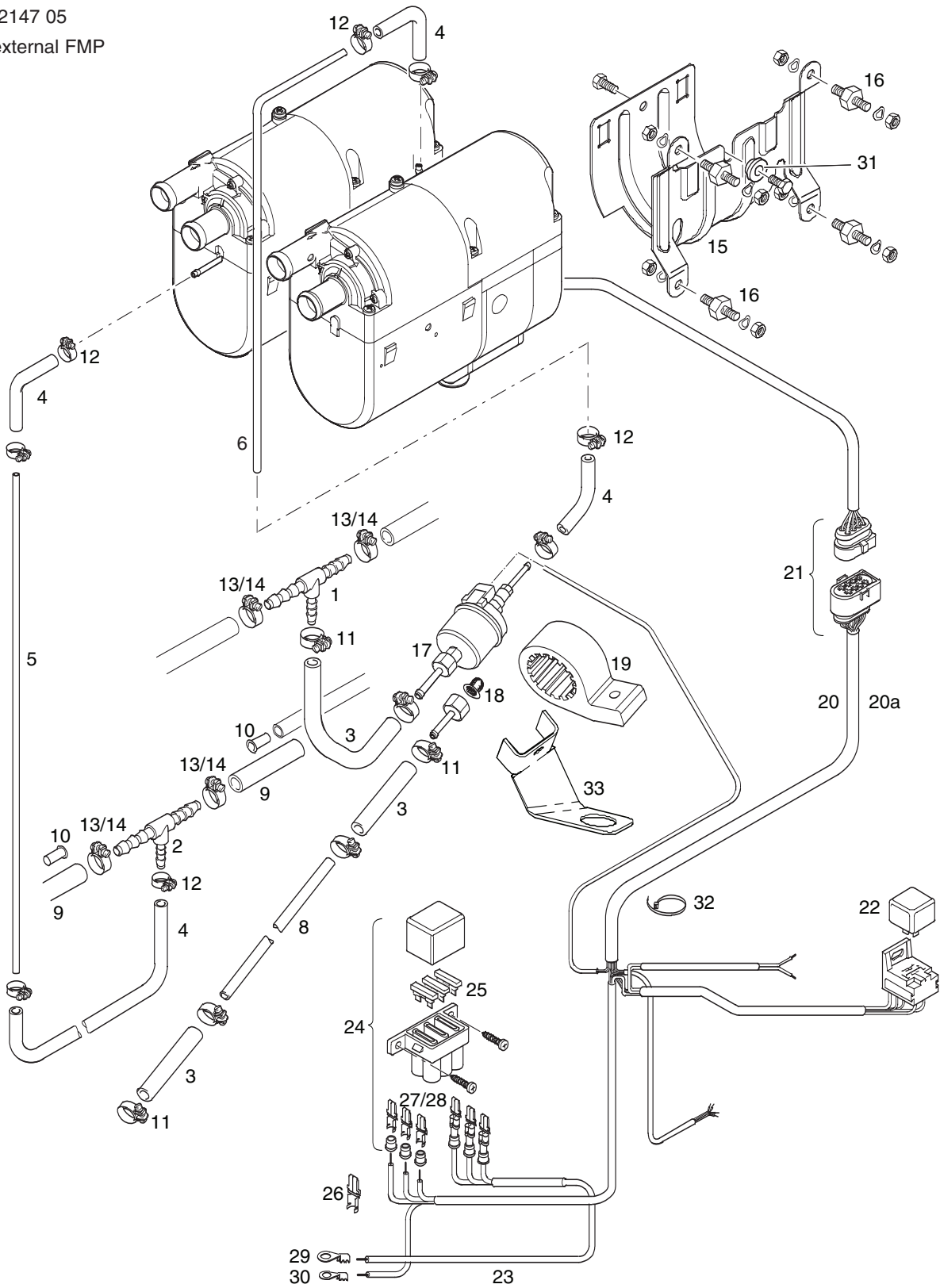



Heater Components

Early "SC" Heaters

Hydronic D4 / D5 - 12 & 24 volt - Diesel & Gasoline versions

Description & Part #'s

Ref. No.	Description	Part Number	Model #	25 2096 05 12V	25 1920 05 12V	25 2098 05 12V	25 2147 05 24V
1	T - piece -8-6-8	262 31 151					•
2	T - piece -8-4-8	262 31 155		•	•	•	
3	Hose 5 x 3mm	----- 360 75 350		•	•	•	•
4	Hose 3.5 x 3mm	360 75 300		•	•	•	•
5	Pipe 2.0mm (optional)	890 31 117		•	•	•	
6	Pipe 1.5mm	890 31 118					•
8	Pipe 2mm	890 31 125					•
9	Hose 7.5mm	----- 360 31 070		•	•	•	•
10	Supporting sleeve with collar	-----		•	•	•	•
11	Hose clip 11mm	25 2068 01 10 98					•
12	Hose clip 9mm	10 2068 00 90 98		•	•	•	•
13	Hose clip 14mm	10 2068 01 40 98		•	•	•	•
14	Hose clip 12mm	10 2068 01 20 98			•	•	•
15	Holder	25 1864 80 00 01		•	•	•	•
16	Metal rubber buffer 6mm	20 1185 00 00 01		•	•	•	•
17	Fuel metering pump	24V 25 1942 45 00 00					•
18	Cap sieve	20 1312 00 00 06					•
19	Holder metering pump	22 1000 50 03 00					•
20	Main harness - J.E. universal w/relay	25 1917 80 11 00 25 2009 80 10 00		•	•	•	•
20a	Main harness ESPAR	20 2900 70 04 01 20 2900 70 05 03 20 2900 70 05 02		•	•		•
21	Connection kit main harness	22 1000 30 10 21		•	•	•	•
22	Relay	203 00 065		•	•	•	•
23	Relay harness	20 1668 80 05 00 22 1000 31 28 00		•	•	•	•
24	Fuse holder Kit	22 1000 31 06 00		•	•	•	•
25	Fuse	25 A 20 A 5 A		•	•	•	•
		204 00 089 5670055 204 00 079		•	•	•	•
26	Terminal Fe	206 52 136		•	•	•	•
26	Terminal Fe	206 52 133		•	•	•	•
28	Terminal Fe	206 52 134		•	•	•	•
29	Eyelet	Hardware		•	•	•	•
30	Eyelet	Hardware		•	•	•	•

Heater Components

Early "SC" Heaters

Hydronic D4 / D5 - 12 & 24 volt - Diesel & Gasoline versions

Description & Part #'s

Ref. No.	Description	Part Number	Model #	25 2096 05 12V	25 1920 05 12V	25 2098 05 12V	25 2147 05 24V
31	Washer	25 1864 80 00 02		•	•	•	•
32	Cable band	25 1801 80 02 00		•	•	•	•
33	Angle bracket	20 2900 40 01 04		•	•	•	•



Notes:

Parts Diagram - Hydronic B4 / B5 / D4 / D5 - 12 & 24 volt - Diesel & Gasoline versions

Model 25 2096 05
Model 25 1920 05
Model 25 2098 05
Model 25 2147 05
with external FMP

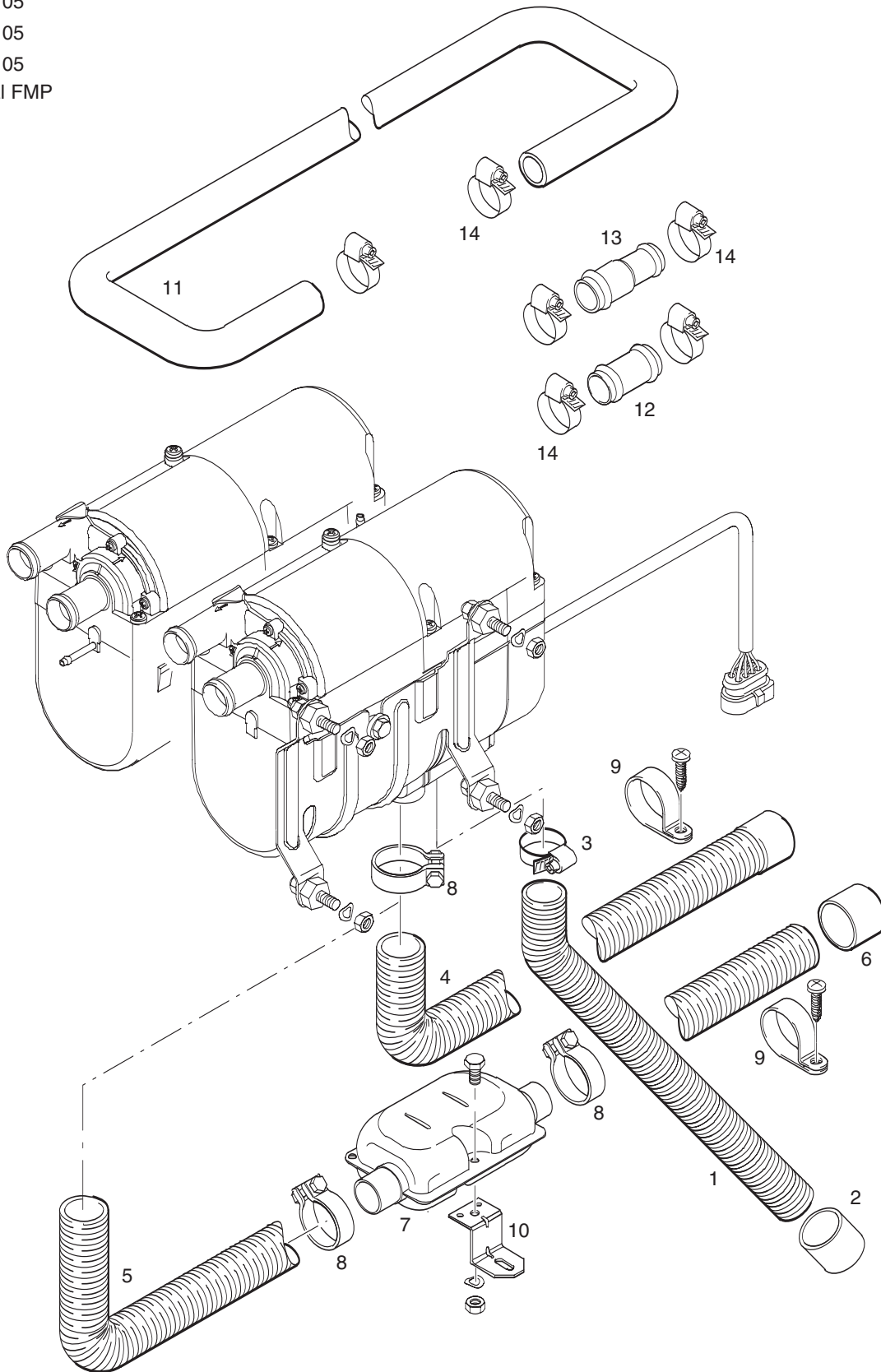



Heater Components

Early "SC" Heaters

Hydronic D4 / D5 - 12 & 24 volt - Diesel & Gasoline versions

Description & Part #'s

Ref. No.	Description	Part Number	Model #	25 2096 05 12V	25 1920 05 12V	25 2098 05 12V	25 2147 05 24V
1	Flexible air intake hose	360 00 099		•	•	•	•
2	End cap with bar	25 1688 80 12 01		•	•	•	•
3	Hose clamp 16 - 25mm	10 2067 01 60 25		•	•	•	•
4	Exhaust hose - 24mm x 1mtr with cap	25 1774 80 02 00		•	•	•	•
5	Exhaust hose - 24mm	360 61 299		•	•	•	•
6	End cap with bar	25 1729 80 06 00		•	•	•	•
7	Exhaust silencer	25 1864 81 01 00		•	•	•	•
8	Exhaust clamp 26mm	152 61 102		•	•	•	•
9	"P" clamp 28mm	152 09 010		•	•	•	•
10	Double angle bracket	20 1533 88 00 07		•	•	•	•
11	Hose - moulded 20mm	25 1917 80 00 01		•	•	•	•
12	Hose union 20mm	20 1534 88 00 01		•	•	•	•
13	Hose union reducer 20-18 mm	20 1645 89 00 06		•	•	•	•
14	Hose clamp 20 - 32mm	10 2065 02 00 32		•	•	•	•

Parts Diagram - Hydronic D4 / D5 - 12 & 24 volt - Diesel & Gasoline versions

Model 25 2096 05
Model 25 1920 05
Model 25 2098 05
Model 25 2147 05
with external FMP

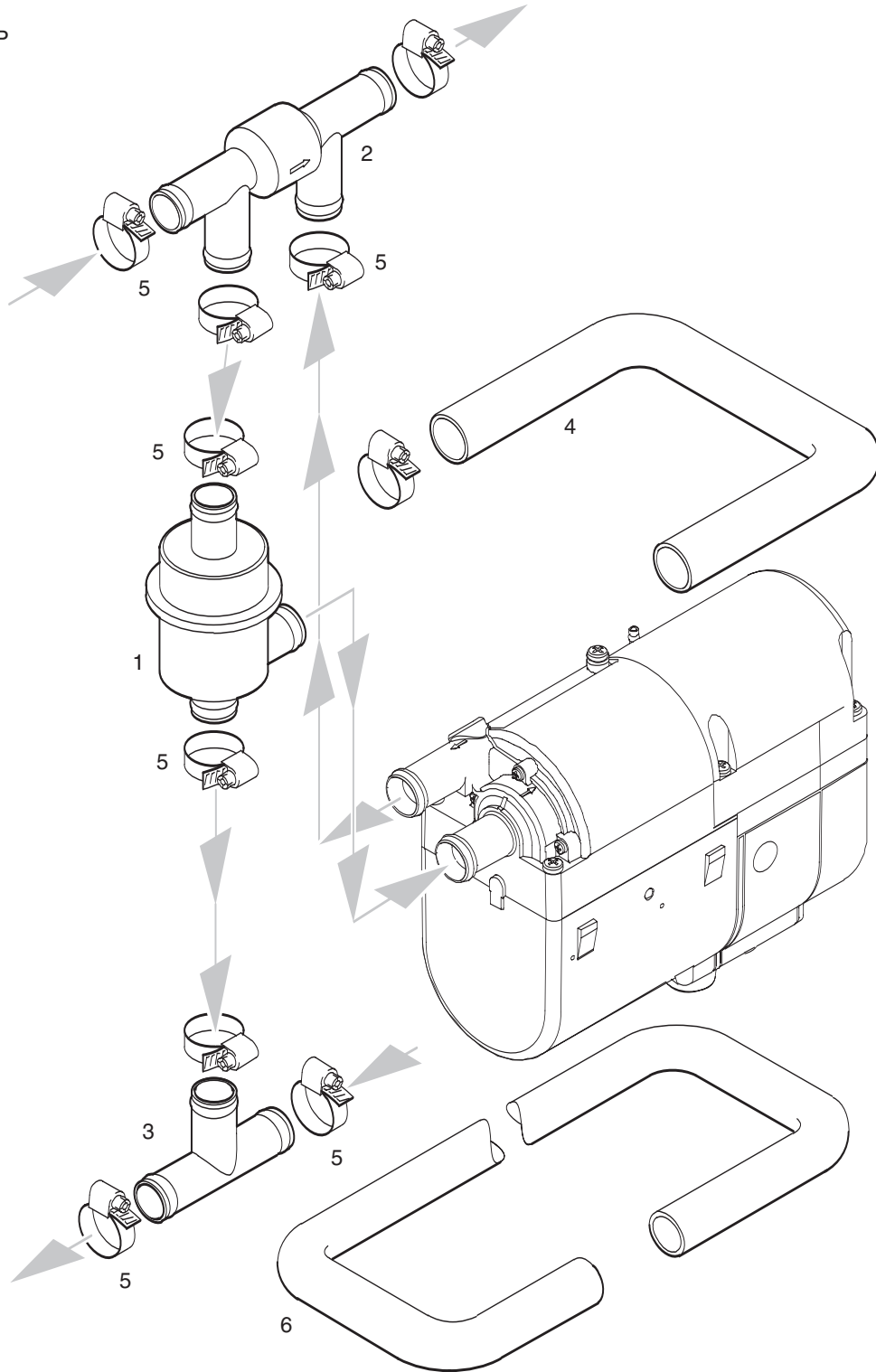

Heater Components

Early "SC" Heaters



Hydronic D4 / D5 - 12 & 24 volt - Diesel & Gasoline versions

Description & Part #'s

Ref. No.	Description	Part Number	Model #	25 2096 05 12V	25 1920 05 12V	25 2098 05 12V	25 2147 05 24V
1	Thermostat	330 00 123			•	•	•
2	One way valve	254 00 074		•			
		254 00 070			•	•	•
3	T - pipe piece Ø 18-18-18 Ø 20-20-20	20 1673 80 11 00		•			
		20 1645 89 10 00			•	•	•
4	Hose - moulded 20mm	24 0117 80 00 01		•			
5	Hose clamp 20 - 32mm	10 2065 02 00 32		•	•	•	•
6	Hose moulded 18mm	24 0132 00 00 01		•	•	•	•

Parts Diagram - Hydronic B5 / D5 - 12 & 24 volt - Diesel & Gasoline versions

Model 20 1793 05
Model 25 2031 05
Model 25 2146 05

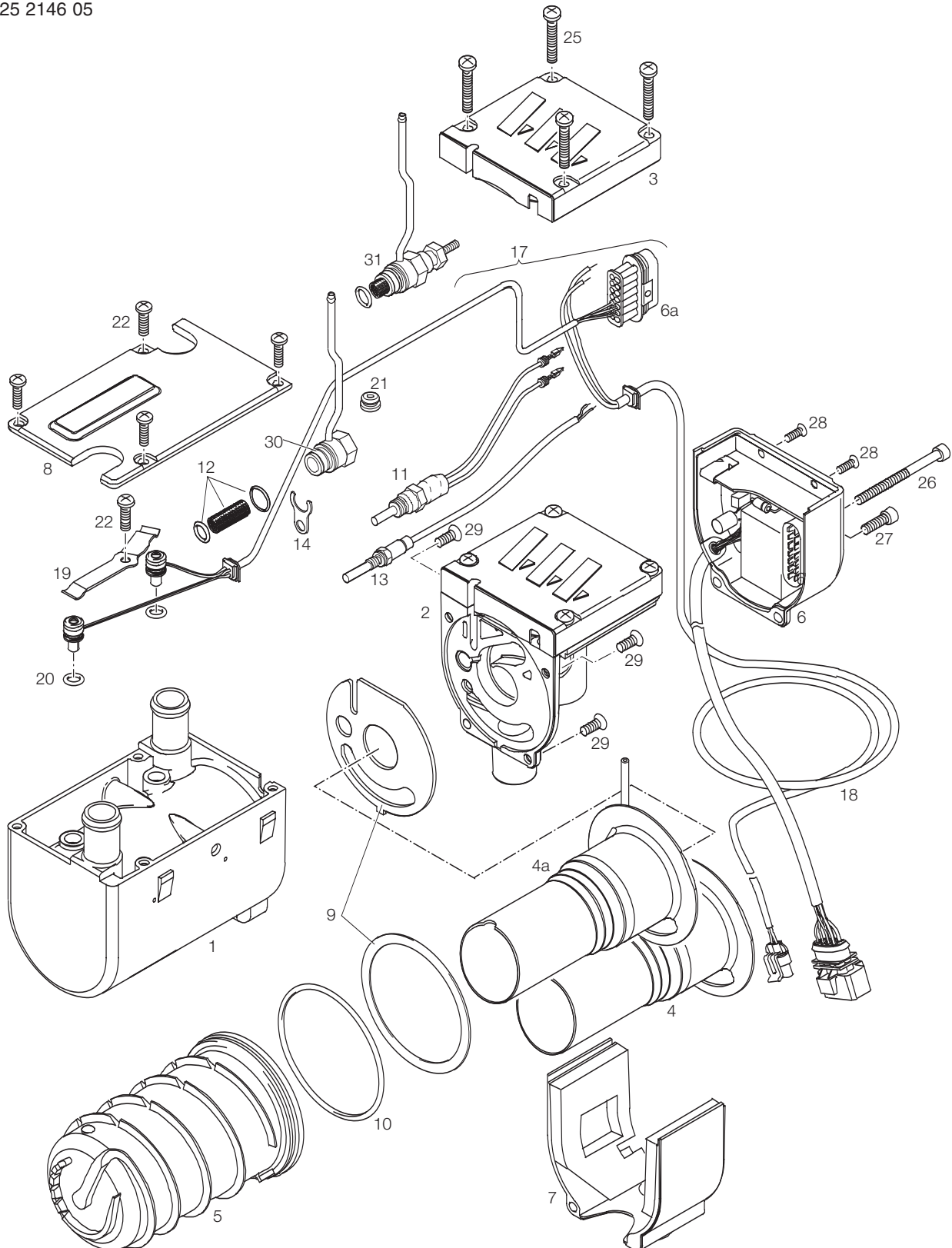



Heater Components

Early "S" Heaters

Hydronic B5 / D5 - 12 & 24 volt - Diesel & Gasoline versions

Description & Part #'s

Ref. No.	Description	Part Number	Model #	20 1793 05 12v	25 2031 05 12v	25 2146 05 24v
1	Casing	25 1922 01 01 01		•	•	•
2	Combustion air blower with cover	20 1819 99 16 00 25 1922 99 16 00 25 2146 99 17 00		•	•	•
3	Cover	20 1756 01 00 03 25 1864 01 00 04		•	•	•
4	Burner	20 1818 10 00 00		•		
4a		25 2146 10 00 00 25 1922 10 00 00			•	•
5	Heat exchanger	25 1922 06 00 01		•	•	•
6	Control unit	22 5201 00 30 02 22 5201 00 20 04 22 5202 01 10 01		•	•	•
6a	Plug kit	22 1000 30 10 10		•	•	•
7	Cover heater base	20 1756 99 01 03		•	•	•
8	Cover blower	25 1922 01 00 02		•	•	•
9	Gasket / seal set	20 1820 99 00 01		•	•	•
10	O-Ring 74 x 3mm	320 75 104		•	•	•
11	Glow pin	12 V 25 2106 01 10 00 24 V 25 2107 01 10 00		•	•	•
12	Lining and 2 O-Rings	20 1752 99 01 02		•		
13	Flame sensor	25 1920 35 00 00		•	•	•
14	Holder	20 1752 01 00 04		•		
17	Over heat / temperature sensors w/cable	25 1942 01 20 00 25 2150 01 20 00		•	•	•
18	Harness, water pump	25 2009 01 15 00		•	•	•
19	Spring	25 1922 01 00 05		•	•	•
20	O-Ring 7 x 2	22 1000 70 00 09		•	•	
21	Grommet	20 1756 01 00 04		•		
22	Taptite screw M5 x 12 Torx	109 10 153		•	•	•
25	Taptite screw M5 x 25 Torx	109 10 152		•		
26	Cheese-head screw M5 x 65 Torx	100 10 350		•	•	•
27	Taptite screw M5 x 16 Torx	109 10 101		•	•	•
28	Taptite screw M4 x 10 Torx	109 10 150		•	•	•
29	Countersunk screw M5 x 12	102 10 302		•	•	•
30	Plug connection	20 1756 01 10 00		•		
31	Plug connection compl.	25 2146 01 13 00				•

Parts Diagram - Hydronic B5 / D5 - 12 & 24 volt - Diesel & Gasoline versions

Model 20 1793 05
Model 25 2031 05
Model 25 2146 05

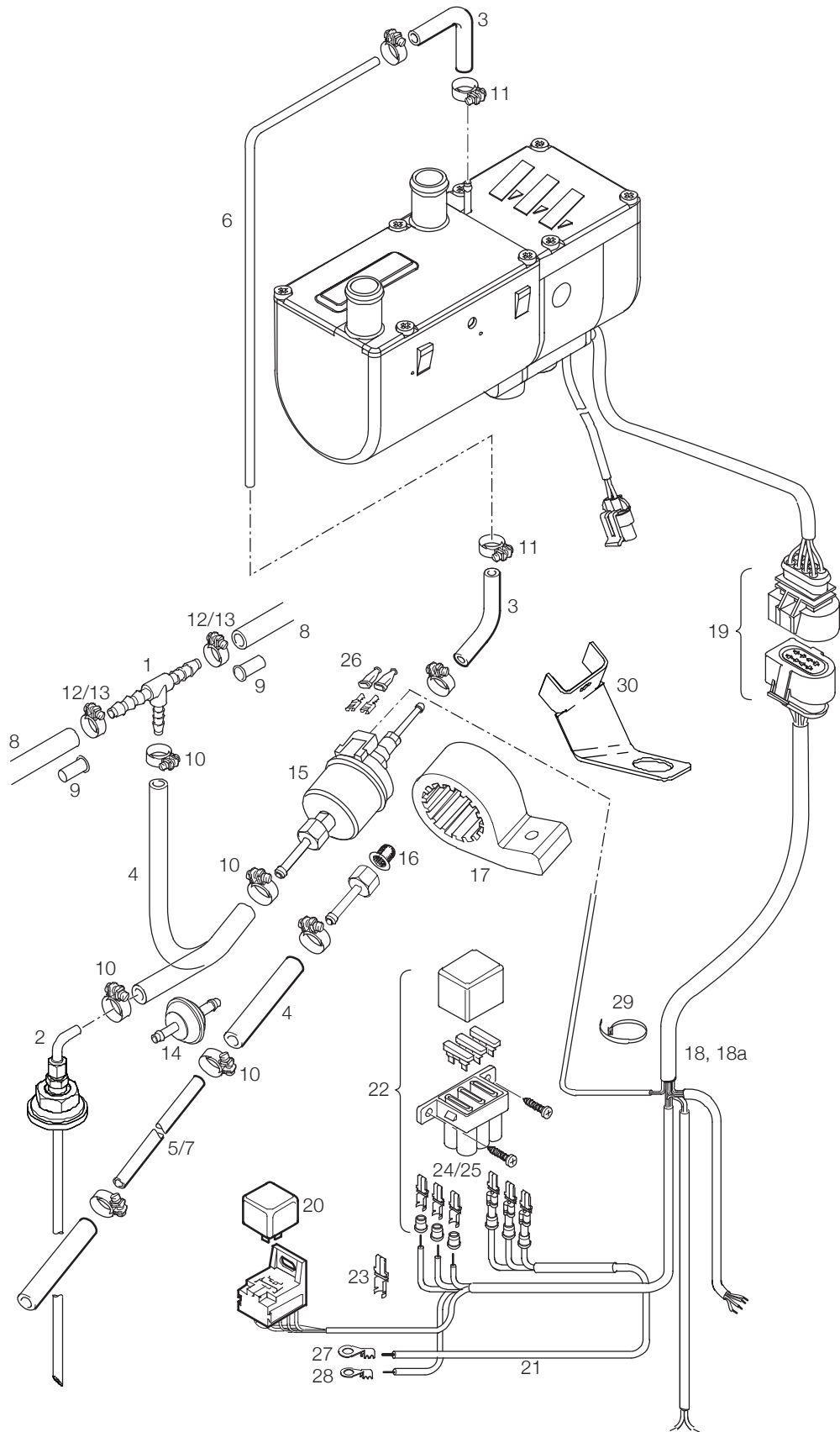



Heater Components

Early "S" Heaters

Hydronic B5 / D5 - 12 & 24 volt - Diesel & Gasoline versions

Description & Part #'s

Ref. No.	Description	Part Number	Model #	20 1793 05 12V			25 2031 05 12V			25 2146 05 24V		
1	T-piece 8 x 6 x 8mm	262 31 151		•	•	•	•	•	•	•	•	•
2	Fuel pick up pipe 2.0mm - Universal	20 2900 20 20 10			•							•
3	Hose 3.5 x 3mm	360 75 300		•	•	•	•	•	•	•	•	•
4	Hose 5 x 3mm	----- 360 75 350		•			•	•				•
5	Pipe 2mm (optional)	890 31 117						•				
6	Pipe 1.5mm	890 31 118		•	•	•	•	•	•	•	•	•
7	Pipe 2mm	890 31 125		•	•	•	•	•	•	•	•	•
8	Hose 7.5mm	360 31 070		•	•	•	•	•	•	•	•	•
9	Supporting sleeve with collar	-----		•	•	•	•	•	•	•	•	•
10	Hose clip 11mm	10 2068 01 10 98		•	•	•	•	•	•	•	•	•
11	Hose clip 9mm	10 2068 00 90 98		•	•	•	•	•	•	•	•	•
12	Hose clip 14mm	10 2068 01 40 98		•	•	•	•	•	•	•	•	•
13	Double angle bracket	10 2068 01 20 98		•	•	•	•	•	•	•	•	•
14	Fuel filter	25 1226 89 00 37					•					•
15	Fuel metering pump	12 V 24 V		•			•	•	•			•
16	Cap sieve	20 1312 00 00 06		•	•	•	•	•	•	•	•	•
17	Holder metering pump	22 1000 50 03 00		•	•	•	•	•	•	•	•	•
18	Main harness - J.E. universal w/relay	25 1917 80 10 00		•			•	•	•			•
18a	Main harness	20 2900 70 05 02		•	•	•	•	•	•	•	•	•
19	Connector kit main harness	22 1000 30 10 21		•	•	•	•	•	•	•	•	•
20	Relay	12 V 24 V		•			•	•	•			•
21	Cable	22 1000 31 28 00		•	•	•	•	•	•	•	•	•
22	Fuse holder kit	22 1000 31 06 00		•	•	•	•	•	•	•	•	•
23	Terminal	206 52 136		•	•	•	•	•	•	•	•	•
24	Terminal	206 52 133		•	•	•	•	•	•	•	•	•
25	Terminal	206 52 134		•	•	•	•	•	•	•	•	•
26	Sleeve	320 31 120		•	•	•	•	•	•	•	•	•
27	Eyelet	Hardware		•	•	•	•	•	•	•	•	•
28	Eyelet	Hardware		•	•	•	•	•	•	•	•	•
29	Cable band	25 1801 80 02 00		•	•	•	•	•	•	•	•	•
30	Angle bracket	20 2900 40 01 04		•	•	•	•	•	•	•	•	•

Parts Diagram - Hydronic B5 / D5 - 12 & 24 volt - Diesel & Gasoline versions

Model 20 1793 05
Model 25 2031 05
Model 25 2146 05

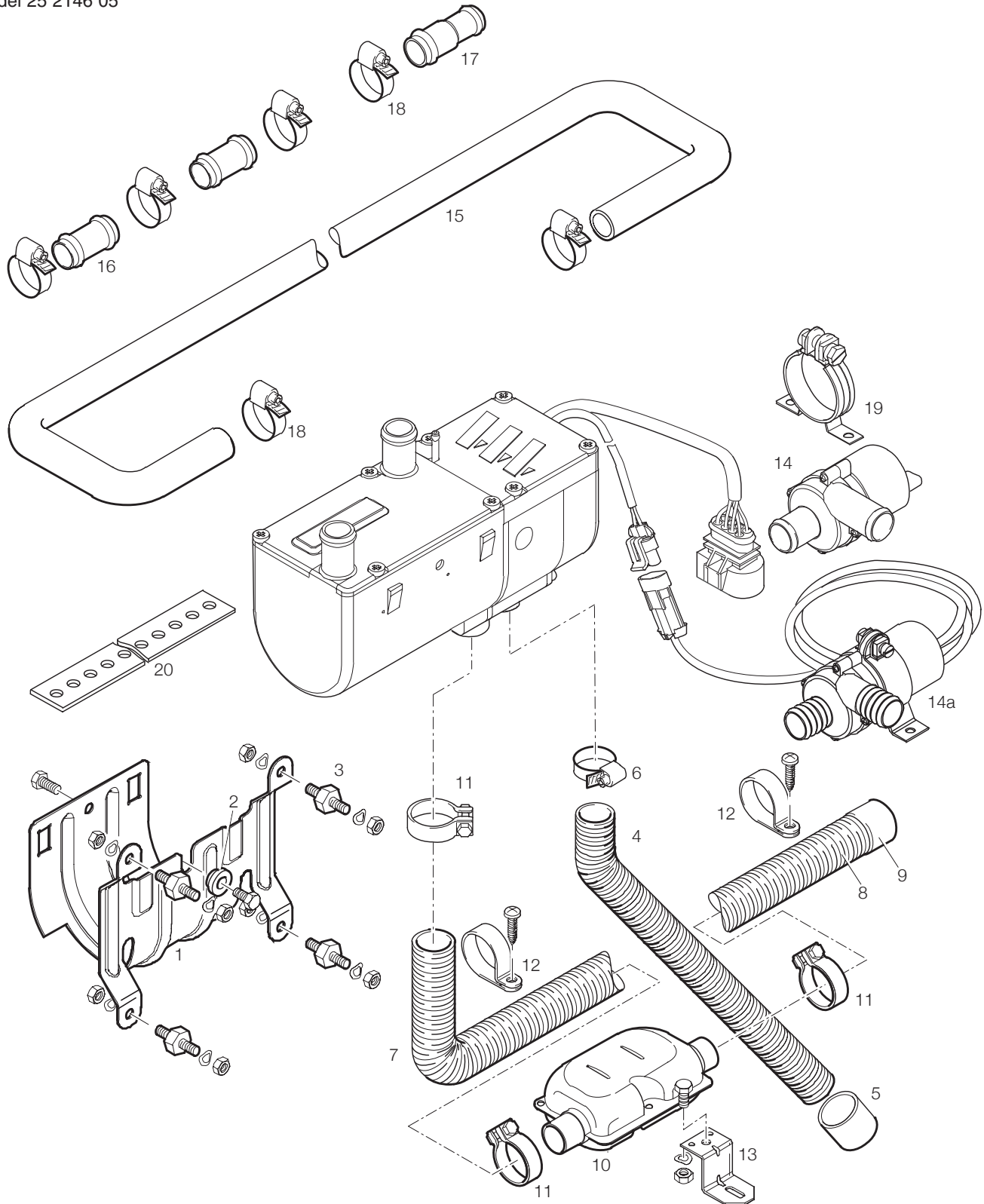



Heater Components

Early "S" Heaters

Hydronic B5 / D5 - 12 & 24 volt - Diesel & Gasoline versions

Description & Part #'s

Ref. No.	Description	Part Number	Model #	20 1793 05 12v	25 2031 05 12v	25 2146 05 24v
1	Bracket	25 1864 80 00 01		•	•	•
2	Spacer	25 1864 80 00 02		•	•	•
3	Metal rubber buffer 6mm	20 1185 00 00 01		•	•	•
4	Air intake hose	360 00 099		•	•	•
5	End sleeve	25 1688 80 12 01		•	•	•
6	Hose clamp 16 - 25mm	10 2067 01 60 25		•	•	•
7	Flexible exhaust w/end cap -1mtr - 24mm	25 1774 80 02 00		•	•	•
8	Flexible exhaust 24mm	360 61 299		•	•	•
9	End sleeve w/bar	25 1729 80 06 00		•	•	•
10	Exhaust silencer	25 1864 81 01 00		•	•	•
11	Clamp 26mm	152 61 102		•	•	•
12	Clamp P type 28mm	152 09 010		•	•	•
13	Holder	20 1533 88 00 07		•	•	•
14	Pump	12 V	330 00 012	•	•	
14a	Pump	24 V	25 2009 25 00 00			•
15	Hose - moulded - 20mm	25 1917 80 00 01		•	•	•
16	Hose union 20mm	20 1534 88 00 01		•	•	•
17	Hose union - reducer 20 - 18	20 1645 89 00 06		•	•	•
18	Hose clamp 20 - 32mm	10 2065 02 00 32		•	•	•
19	Pump clamp	22 1000 50 10 00		•	•	
20	Holder / Bracket with holes	20 1819 80 04 00		•	•	•

Parts Diagram - Hydronic D4 / D5

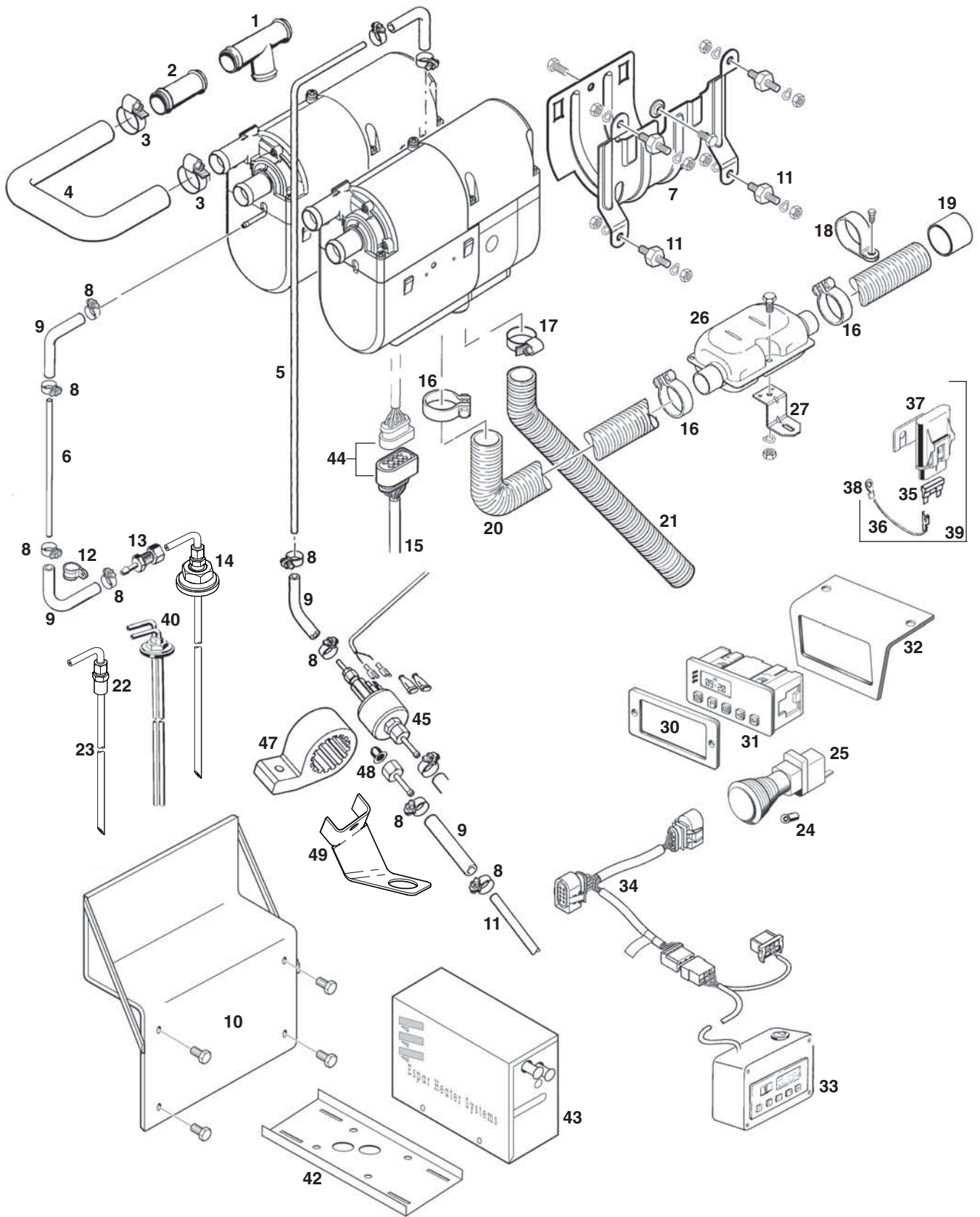



Parts Diagram - Hydronic D4 / D5 - (including Face Lift)

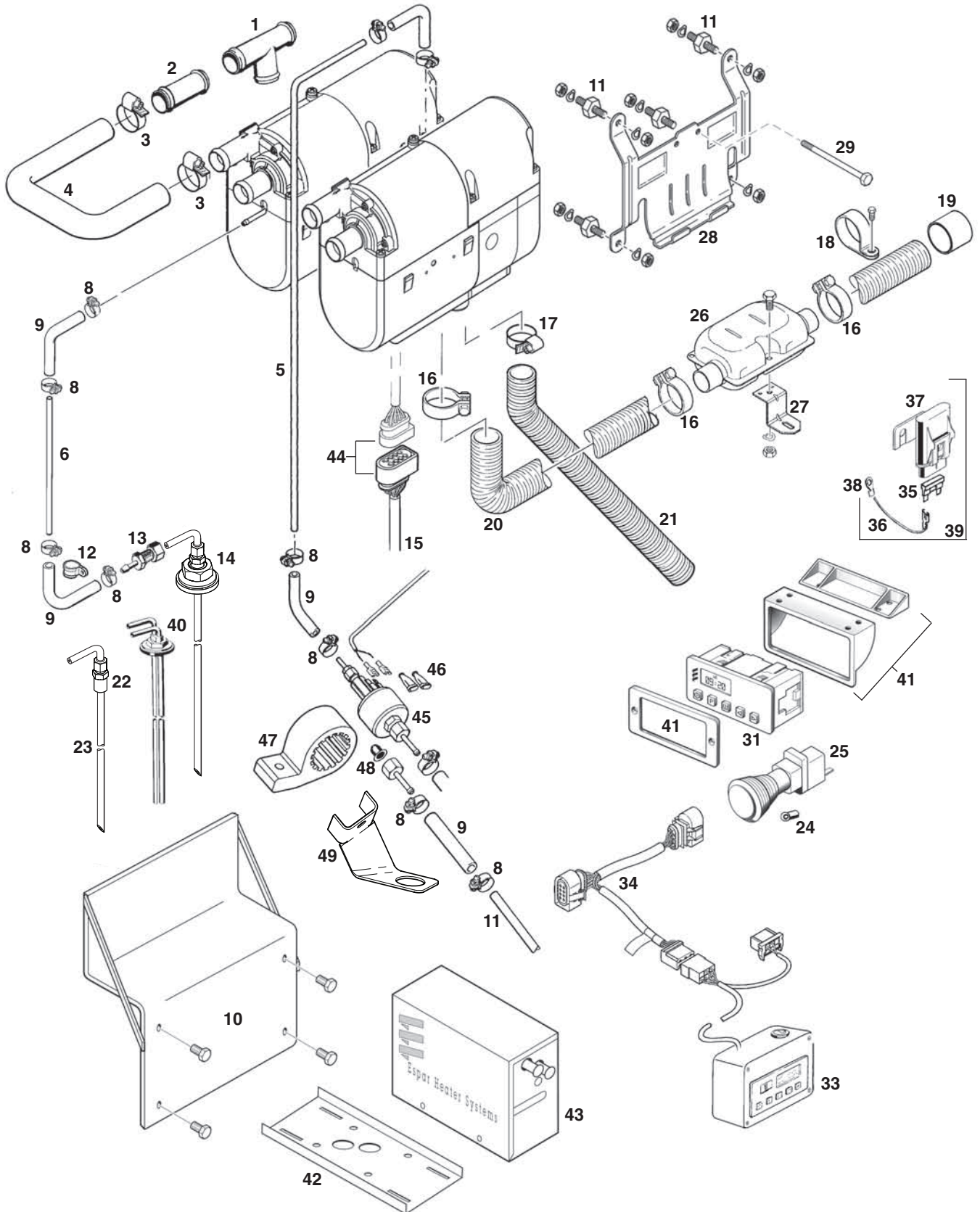

Heater Components

North American

HYDRONIC 4 / 5 SC - Diesel & Gasoline versions

Description & Part #'s

Ref. No.	Description	Part Number	Model #	25 2096 05 12V	25 1920 05 12V	25 2098 05 12V	25 2147 05 24V
1	T-piece, 20mm	20 1673 80 11 00		•	•	•	•
2	Connecting pipe 20mm	20 1534 88 00 01		•	•	•	•
3	Clamp 20mm-32mm	10 2065 02 00 32		•	•	•	•
4	Hose 20mm	25 1917 80 00 01		•	•	•	•
5	1.5m white plastic fuel line	890 31 118					•
6	Fuel line 2mm	890 31 117		•	•	•	•
7	Heater bracket	25 1864 80 00 01		•	•	•	•
8	Hose clamp 9mm	10 2068 00 90 98		•	•	•	•
9	Fuel hose 3.5mm	360 75 300		•	•	•	•
10	Bracket - class 8 truck	20 2900 40 00 85		•	•	•	•
11	Rubber mount 6mm	20 1185 00 00 01		•	•	•	•
12	Pipe clamp 10mm	152 00 139		•	•	•	•
13	Fuel pipe reducer 3.5 - 5mm	25 1888 80 01 02		•	•	•	•
14	Fuel pick up pipe 2.0mm - Universal	20 2900 20 20 10		•	•	•	•
15	Main heater harness	20 2900 70 04 01 20 2900 70 05 03 20 2900 70 20 13		•	•	•	•
16	Exhaust clamp 26mm	152 61 102		•	•	•	•
17	Intake hose clamp	10 2065 02 00 32		•	•	•	•
18	C clamp 28mm	152 09 010		•	•	•	•
19	End sleeve for exhaust	25 1729 80 06 00		•	•	•	•
20	Exhaust hose	360 61 299		•	•	•	•
21	Air intake hose	360 00 099		•	•	•	•
22	Compression fitting	1/4" NPT 20 2900 20 20 44 3/8" NPT 552 0002 1/2" NPT 552 0006		•	•	•	•
23	Custom straight pick up pipe w/Ferrule 24" length	20 2900 20 20 02		•	•	•	•
24	Replacement bulb	12V 207 00 005 24V 207 00 006		•	•	•	•
25	Push/pull switch	12V 567 0007 24V 567 0008		•	•	•	•
26	Muffler 24mm	25 1864 81 01 00		•	•	•	•
27	Double angle bracket	20 1533 88 00 07		•	•	•	•
28	Complete bracket kit for 7-day timer	25 1482 70 01 00		•	•	•	•
29	Hex Bolt	100 10 258		•	•	•	•
30	7 day timer bezel	25 1482 70 01 00		•	•	•	•
31	7 day timer	22 1000 30 36 00		•	•	•	•
	7 day timer with kit (harness & relay)	12 V 20 2900 70 01 35		•	•	•	•
	7 day timer with kit (harness & relay)	24 V 20 2900 70 01 36		•	•	•	•



HYDRONIC 4 / 5 SC - Diesel & Gasoline versions

Description & Part #'s

Ref. No.	Description	Part Number	Model #	25 2096 05 12V	25 1920 05 12V	25 2098 05 12V	25 2147 05 24V
32	Bracket for 7 day timer	20 2900 40 01 58		•	•	•	•
33	Fault code retrieval device	20 2900 70 50 20		•	•	•	•
34	Retrieval harness for fault code device	20 2900 70 50 28		•	•	•	•
35	Fuse blade	25 A	204 00 089	•	•	•	•
		20 A	5670055				•
36	Wire awg 12 gage red	5670117		•	•	•	•
37	Main fuse holder	5670051		•	•	•	•
38	Ring terminal 3/8" awg 10-12	5670178		•	•	•	•
39	Fuse link power harness	20 2900 70 51 08		•	•	•	•
40	Double pick-up (used with combo kits)	20 2900 20 20 57		•	•	•	•
41	7 day timer bracket and Cosmetic Bezel	25 1482 70 01 00		•	•	•	•
42	Cross frame mounting bracket			•	•	•	•
				•	•	•	•
43	Hydronic box Base	25 2800 40 05 02		•	•	•	•
	Hydronic box Lid	25 2800 40 05 01		•	•	•	•
44	Plug Cables Complete	22 1000 30 10 21		•	•	•	•
45	Fuel metering pump	25 1942 45 00 00					•
46	Boot sleeve	320 31 120					•
47	Fuel metering pump holder	22 1000 50 03 00					•
48	Fuel filter	20 1312 00 00 06		•	•	•	•
49	Angle bracket	20 2900 40 01 04		•	•	•	•

Web Edition - September 2009
Subject to change
P/N: 20 2900 81 0121

Espar Products, Inc.

(800) 387-4800

(905) 670-0960

www.espar.com

A member of the Worldwide **Eberspächer** Group of Companies